

# CPU2

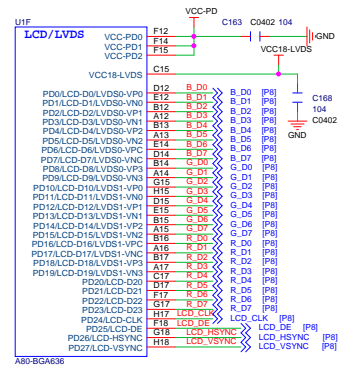

File	CC_A80_MINIPC_SCH_Design		
Size	Document Number	http://cubieboard.org	Rev V1.1
Date:	Sheet	2	of 14

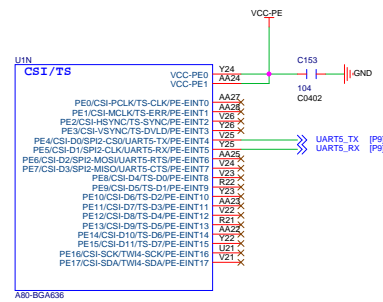
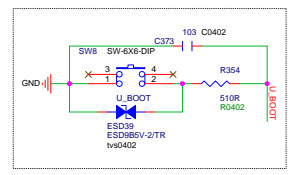
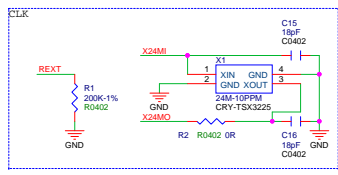
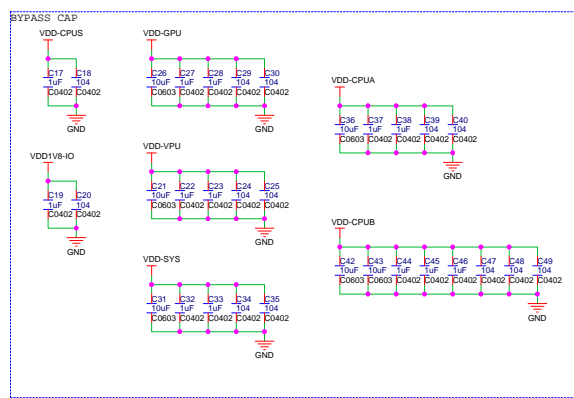
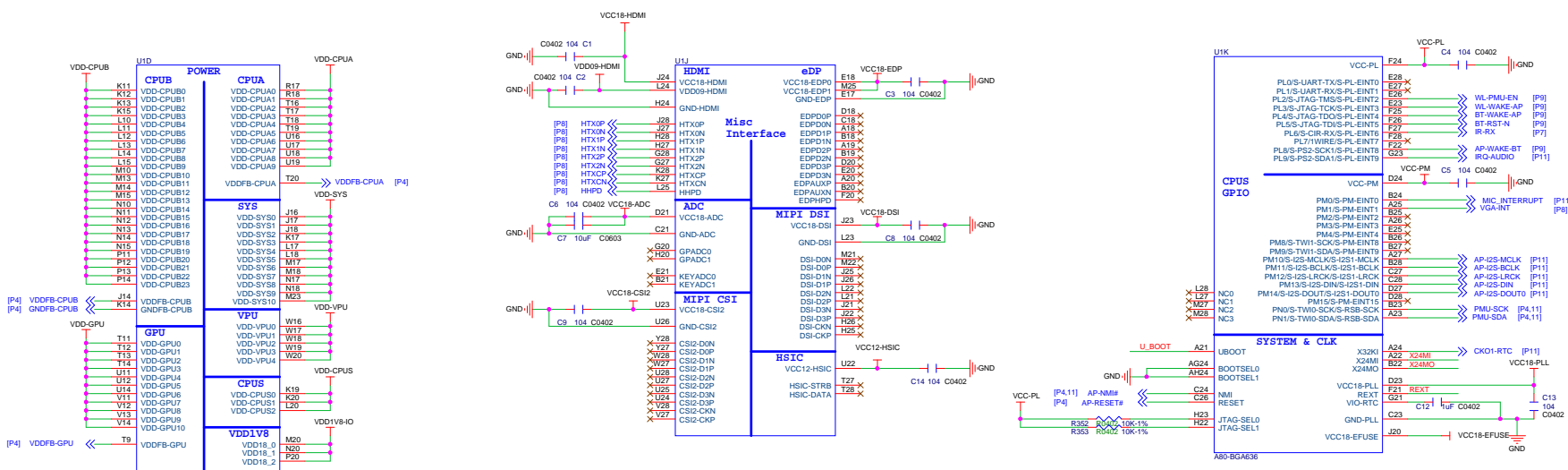
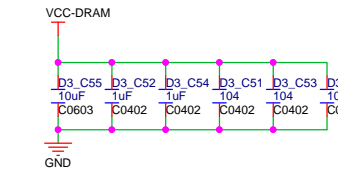
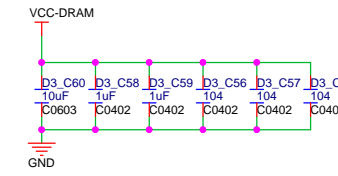
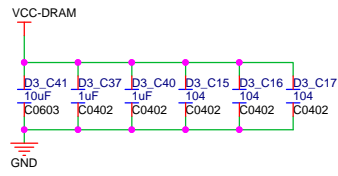
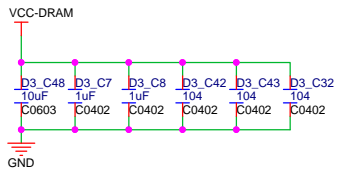
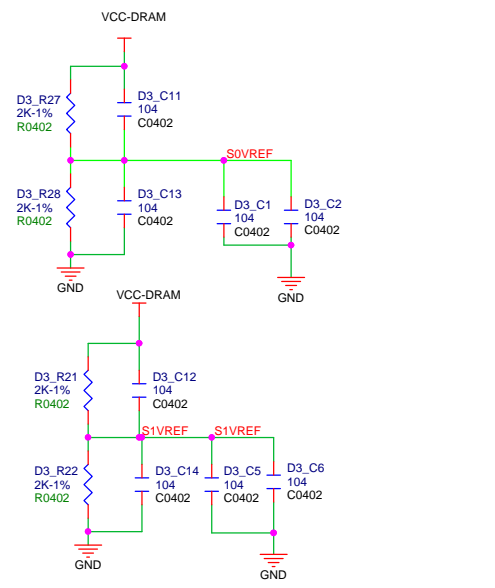
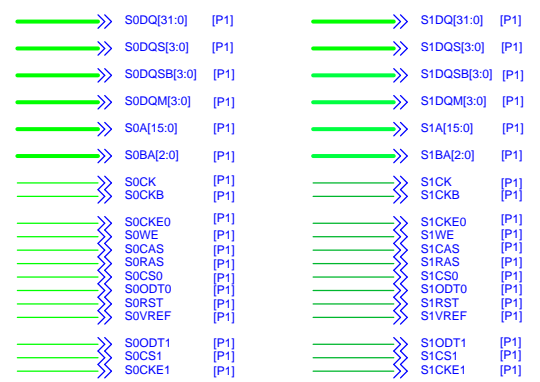
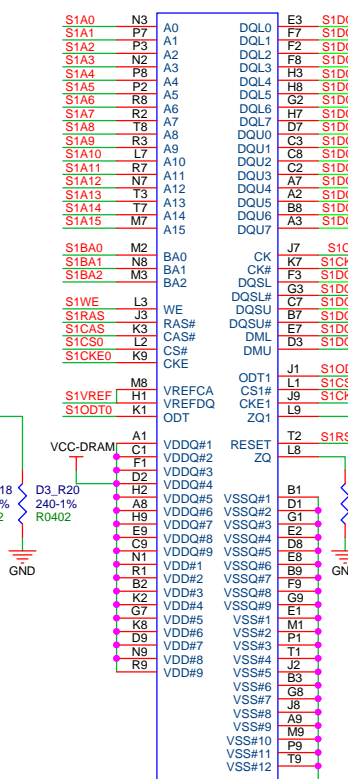
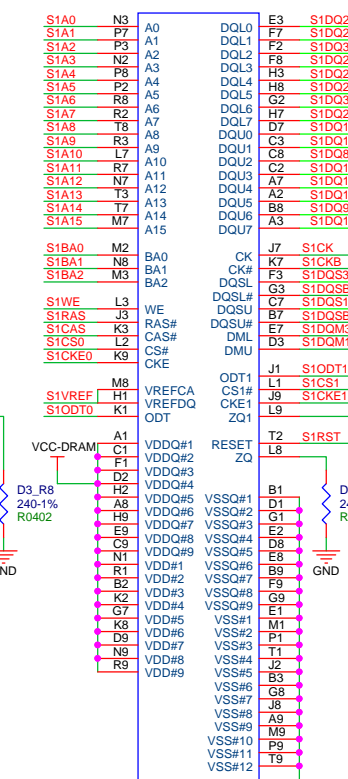
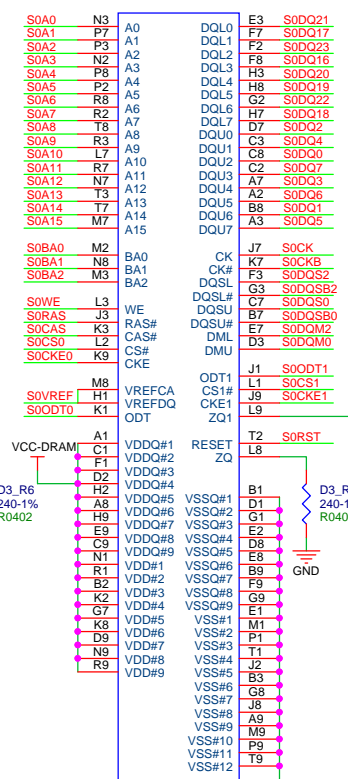
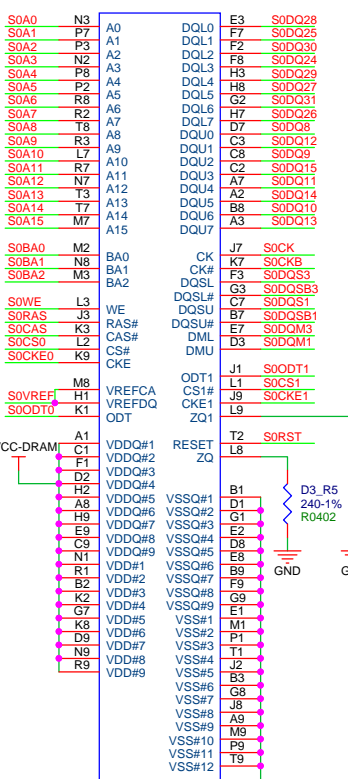

# AXP806

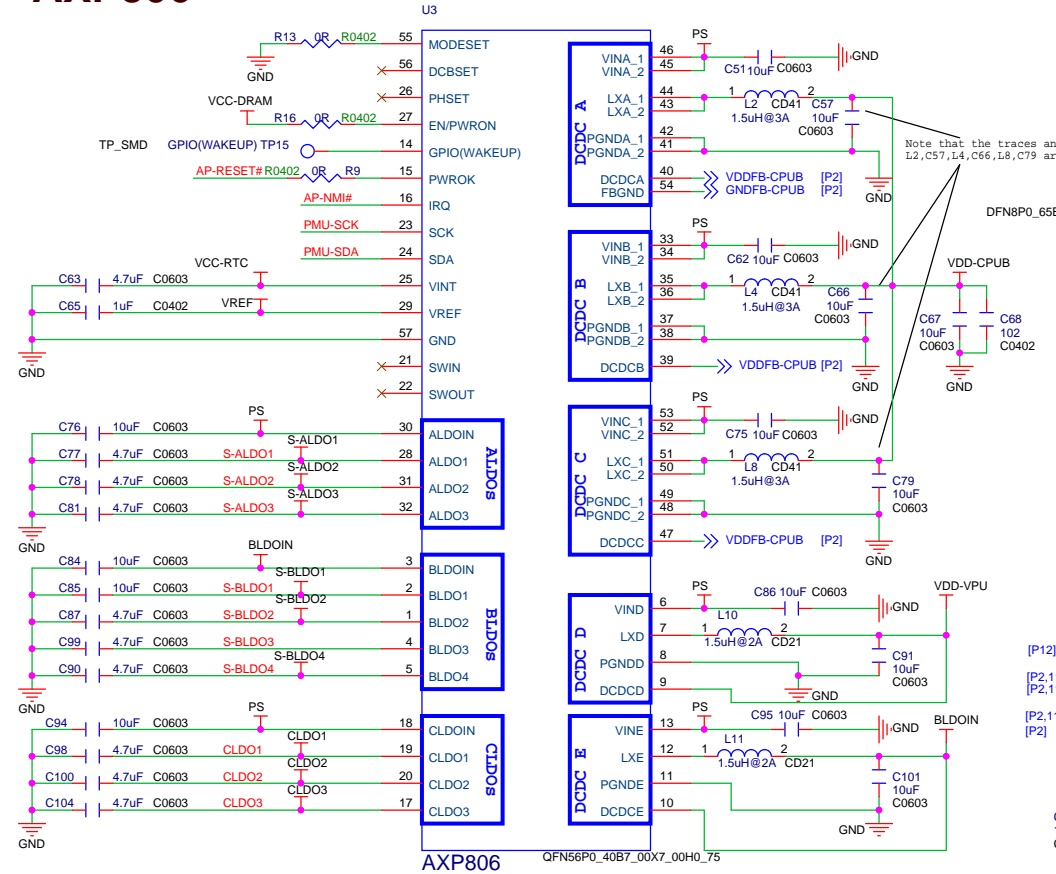

# AXP809

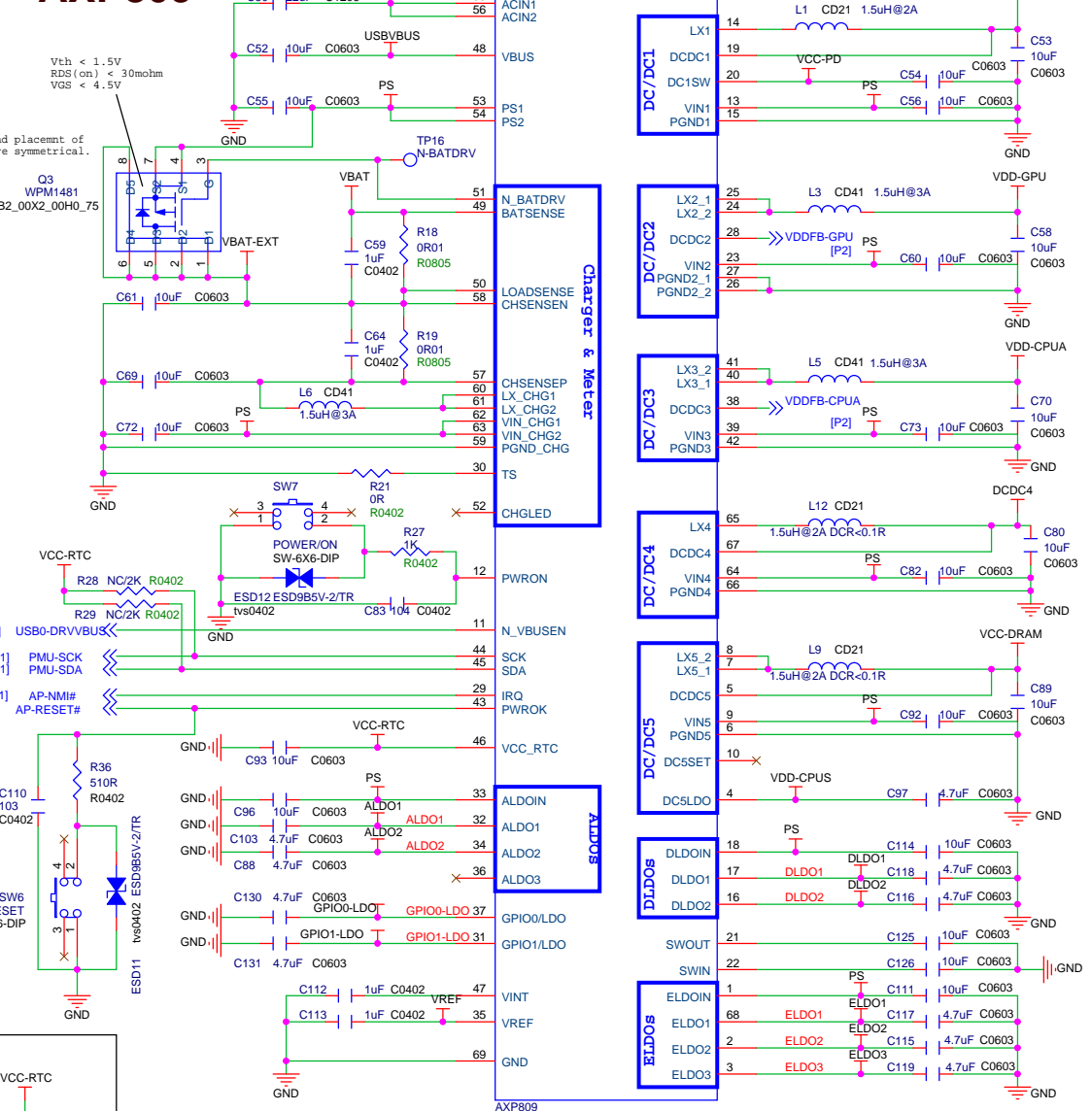

## RTC Backup battery Circuit

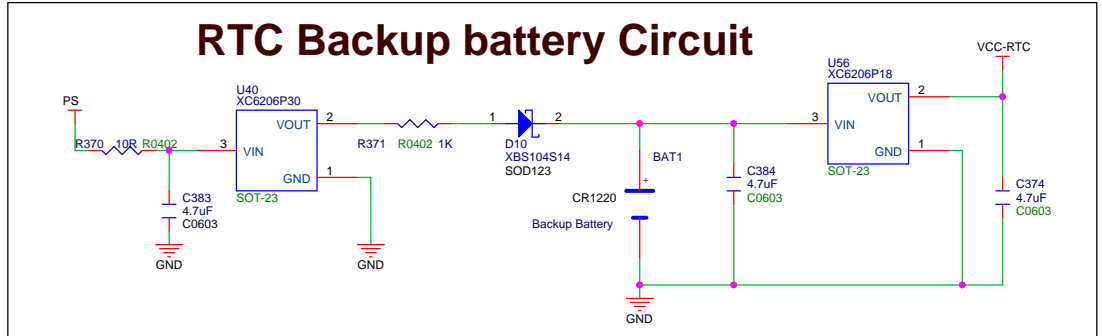

Title <b>CC_A80_MINIPC_SCH_Design</b>		
Size A3	Document Number <a href="http://cubieboard.org">http://cubieboard.org</a>	Rev V1.1
Date:	Sheet 4 of 14	

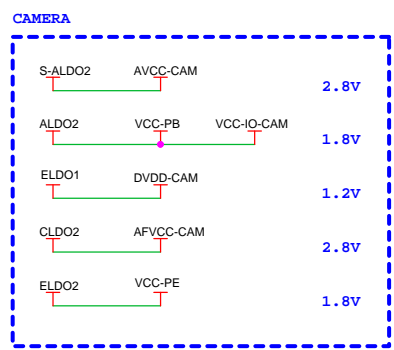
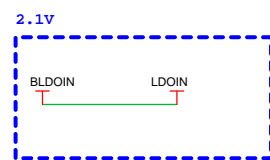
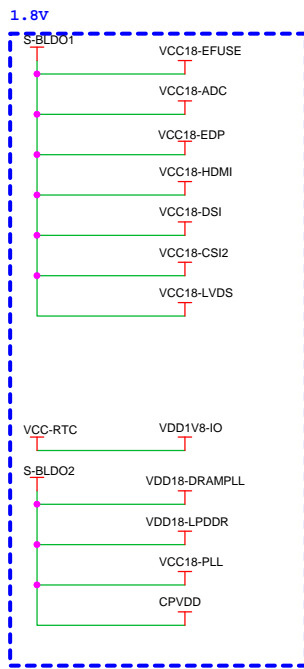
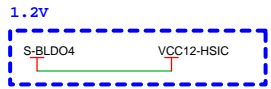
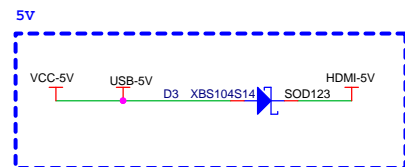
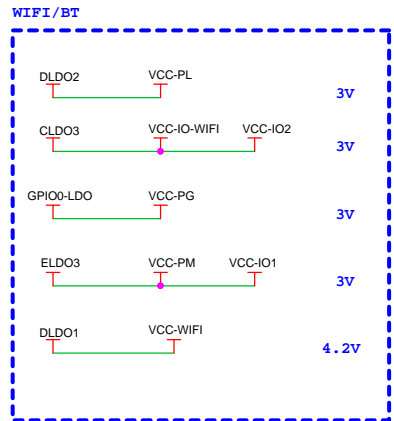
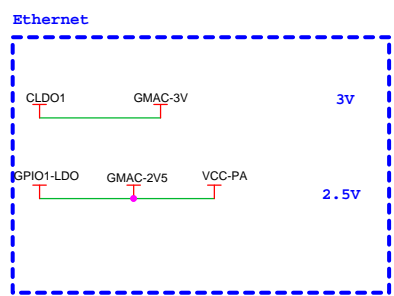
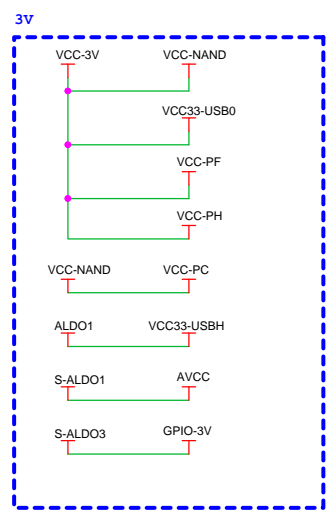
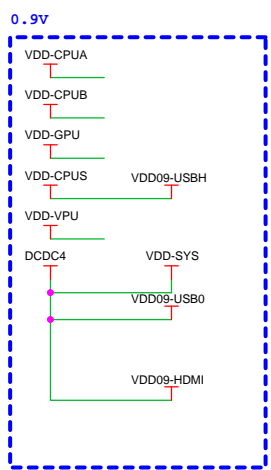
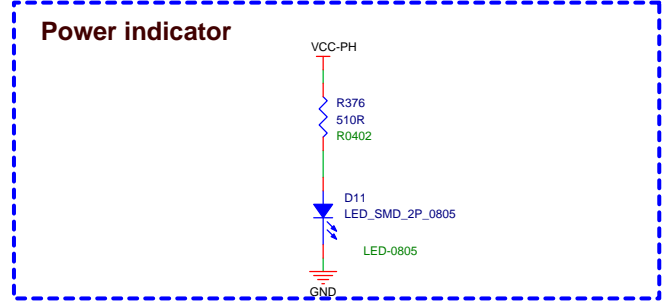
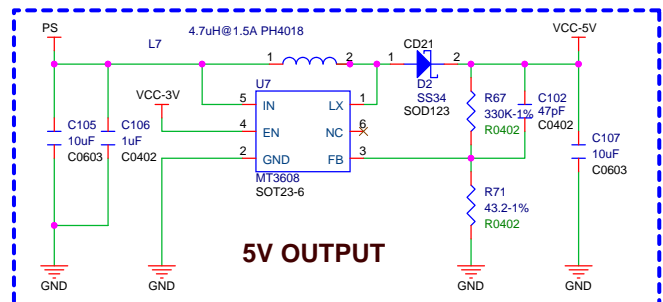
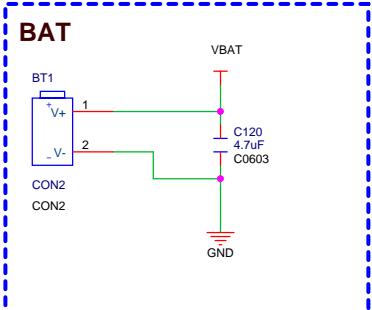
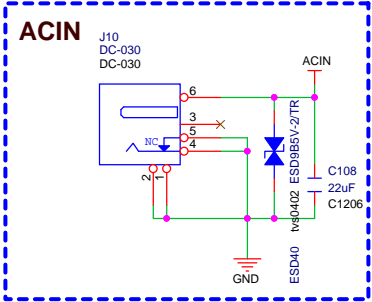

Title		
CC_A80_MINIPC_SCH_Design		
Size	Document Number	Rev
A3	<a href="http://cubieboard.org">http://cubieboard.org</a>	V1.1
Date:	Sheet	of
	5	14

# SPI FLASH/eMMC

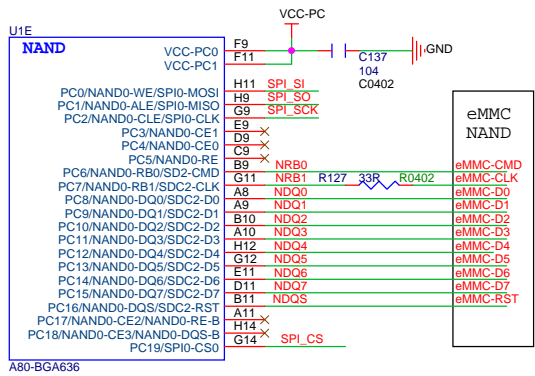

Both eMMC NAND and first TSOP NAND layout together

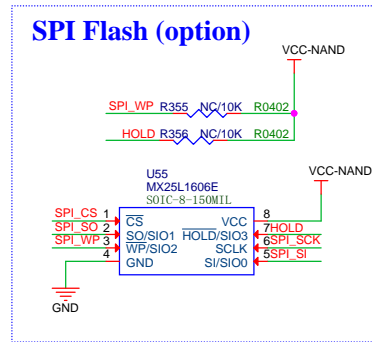
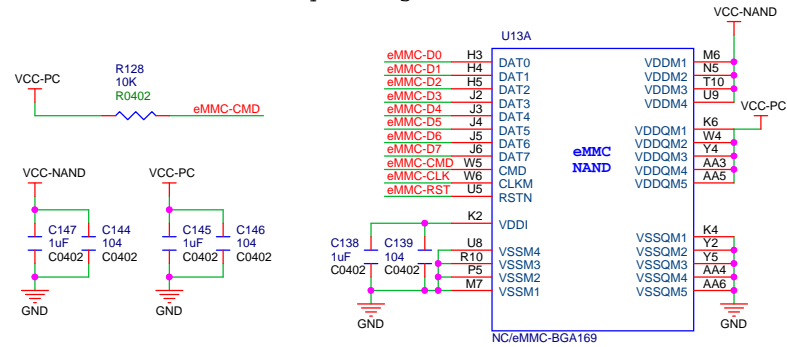

# SD Card

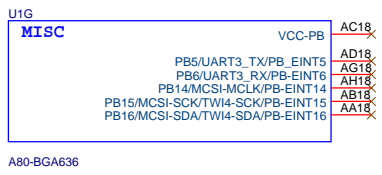
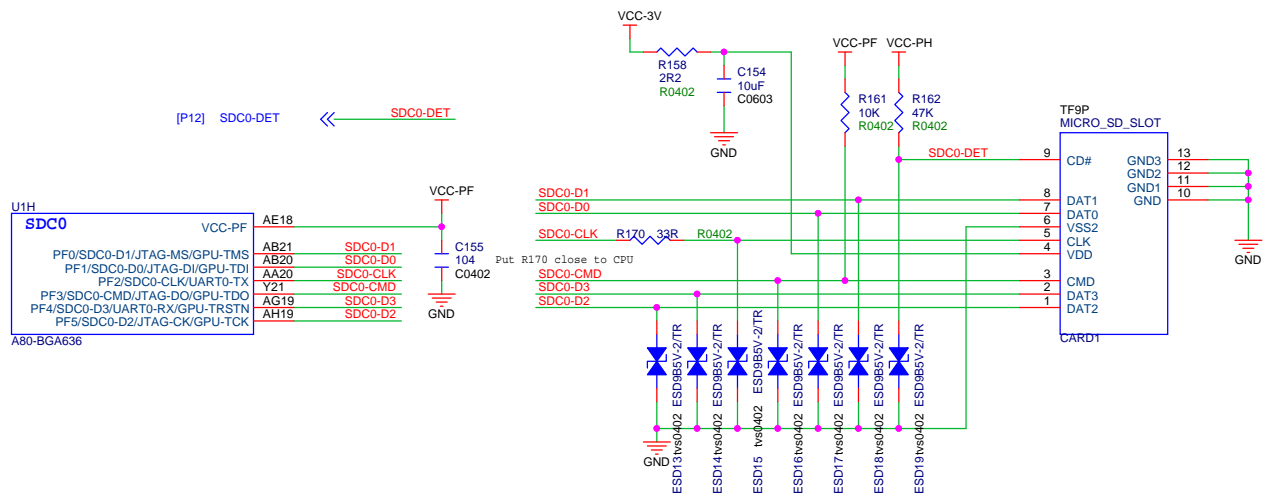

# LED-Indicator

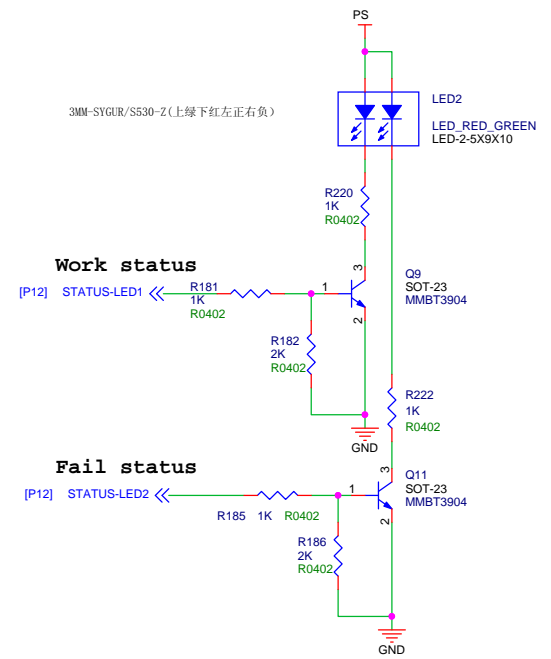

# IR

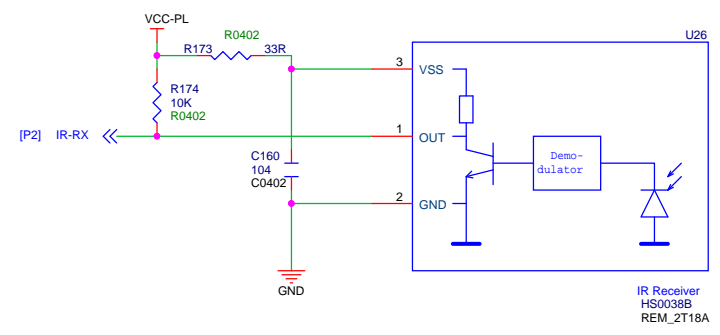

Title		
CC_A80_MINIPC_SCH_Design		
Size	Document Number	Rev
A3	<a href="http://cubieboard.org">http://cubieboard.org</a>	V1.1
Date:	Sheet	7 of 14

# HDMI Interface

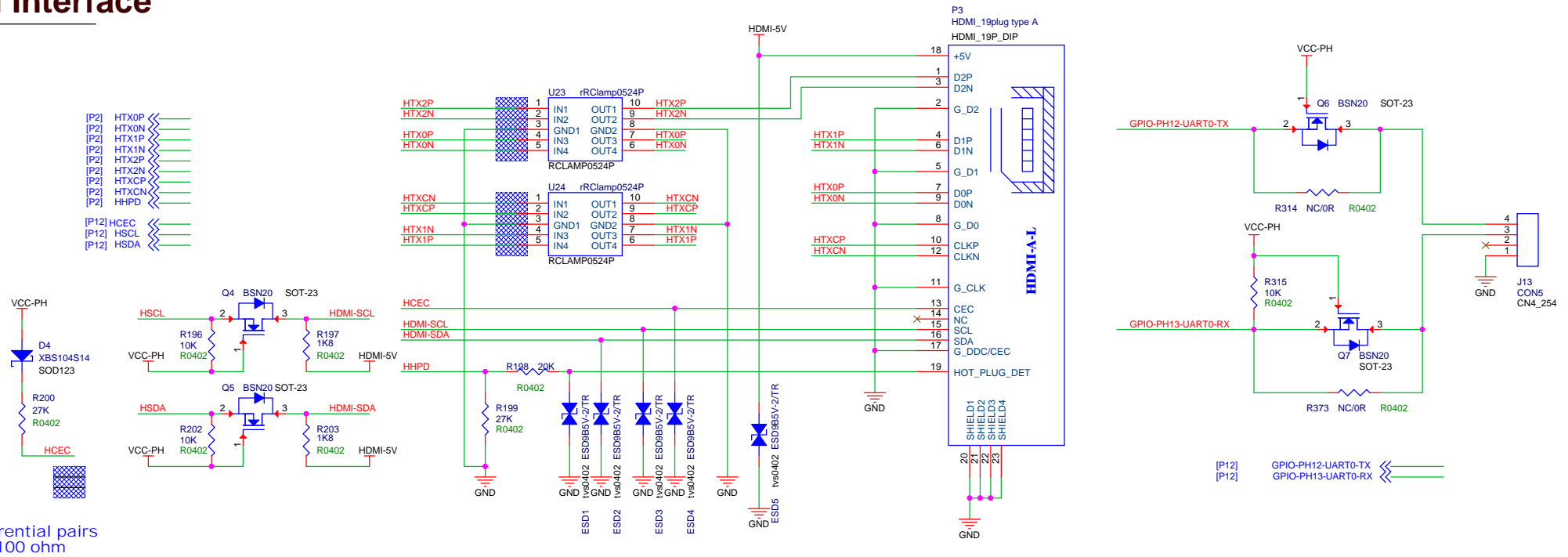

# RGB to VGA Conversion

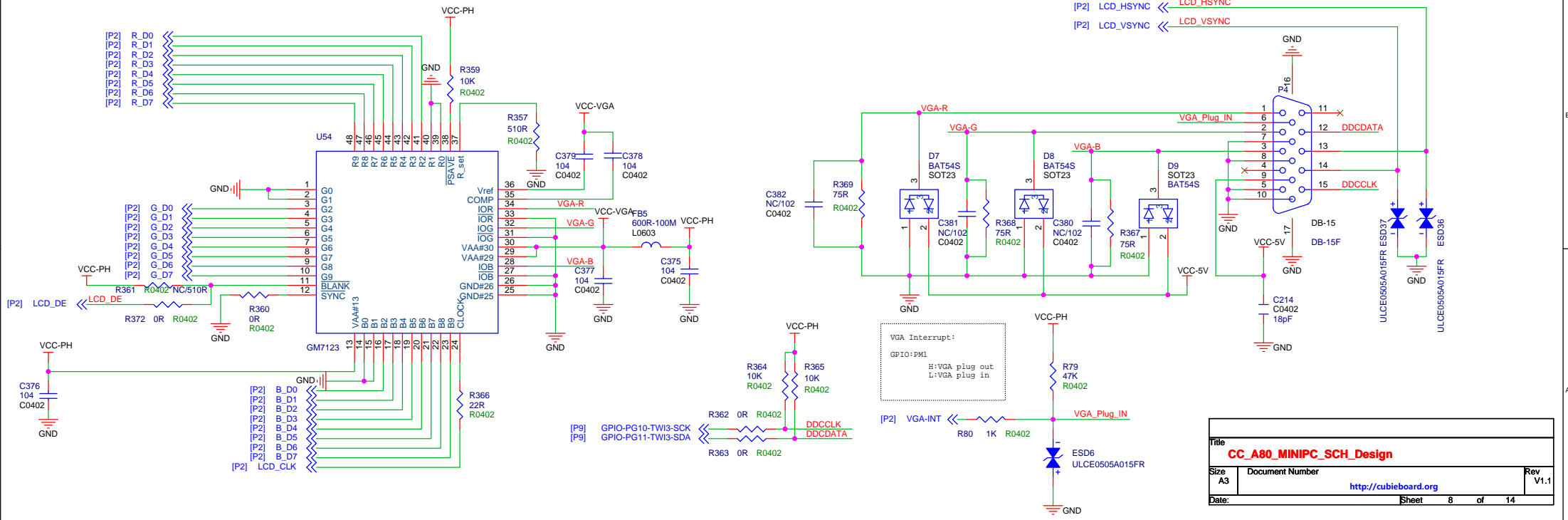



# WIFI/BT

[P11] BT-PCM-CLK <--> BT-PCM-CLK  
 [P11] BT-PCM-SYNC <--> BT-PCM-SYNC  
 [P11] BT-PCM-DIN <--> BT-PCM-DIN  
 [P11] BT-PCM-DOOUT <--> BT-PCM-DOOUT  
 [P11] CODEC-32K <--> AP-CK32KO

[P2] WL-PMU-EN <--> WL-REG-ON  
 [P2] WL-WAKE-AP <--> WL-WAKE-AP

[P2] BT-WAKE-AP <--> BT-WAKE-AP  
 [P2] BT-RST-N <--> BT-RST-N  
 [P2] AP-WAKE-BT <--> AP-WAKE-BT

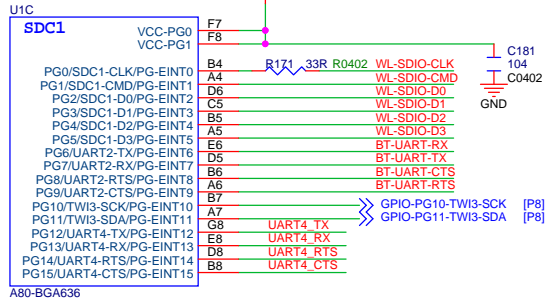

Note:  
 For VCC-IO-WIFI = 1.8V, R204 = 0R  
 For VCC-IO-WIFI = 3.0V, R204 = 3K

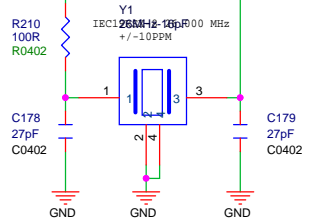
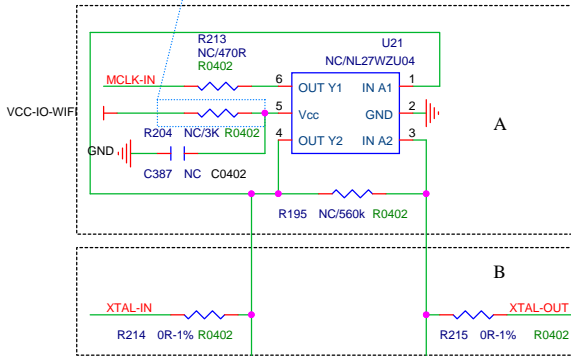

Note:  
 For AP6210, install A+C  
 For AP6330/AP6181, install B

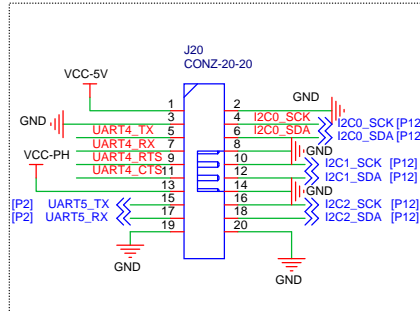

## Software Protect IC

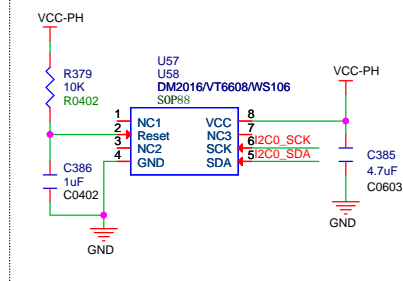

There should be ground clearance around antenna.

C184 and C183 are tuning elements.

C184:GRM1555C1H1R8CA01  
 C183:GRM1555C1H1R5CA01  
 C182:GRM1555C1H2207A01

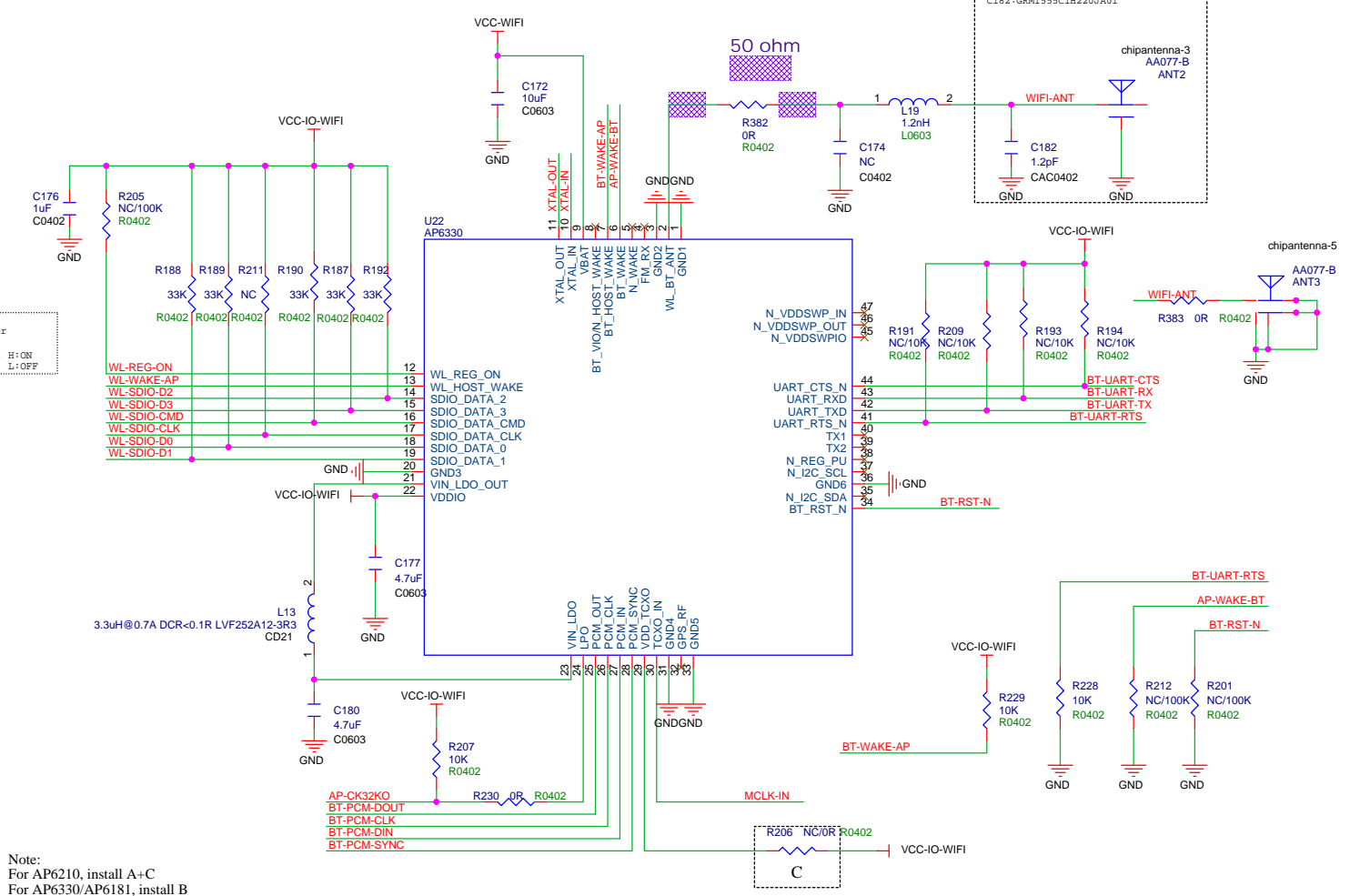

Title		
CC_A80_MINIPC_SCH_Design		
Size	Document Number	Rev
A3		V1.1
Date:	http://cubieboard.org	
	Sheet	9 of 14

# ETHERNET

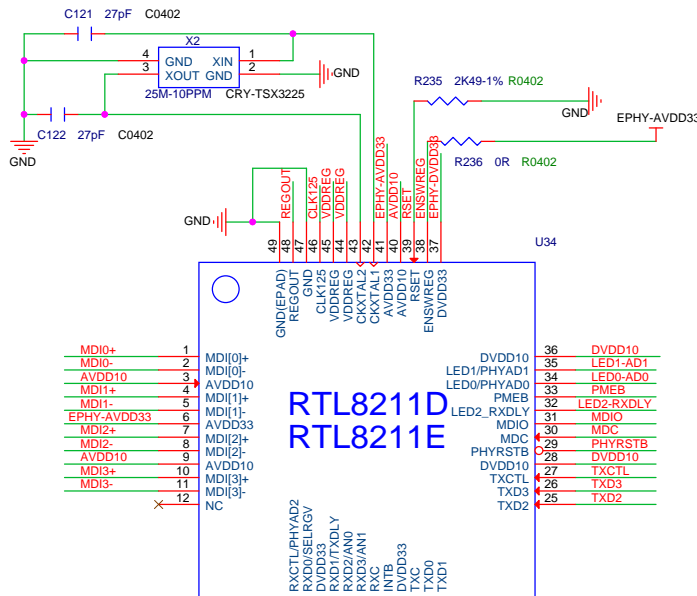
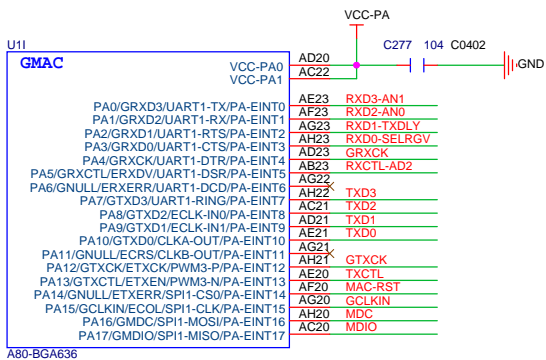

The placement of R258 R259 C358 C360 is close to PHY.  
The placement of R260 C361 is close to AP.

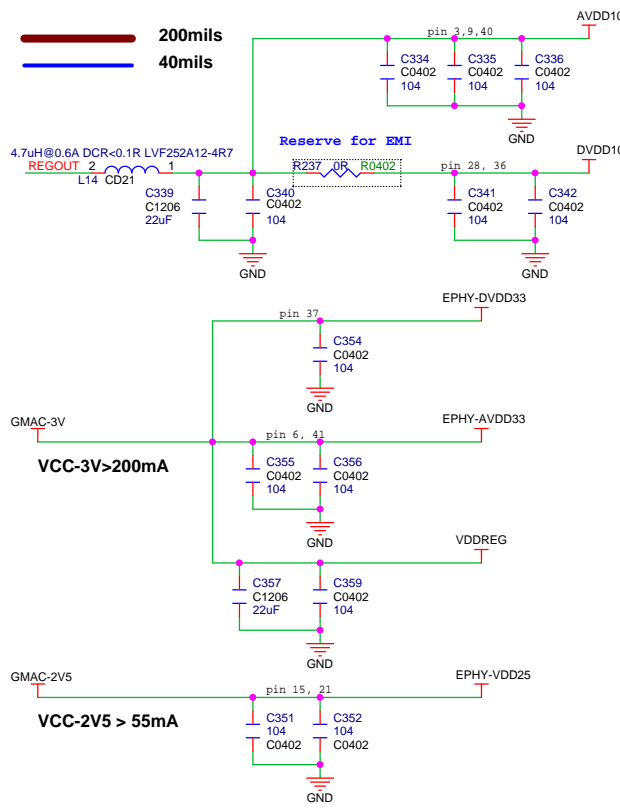
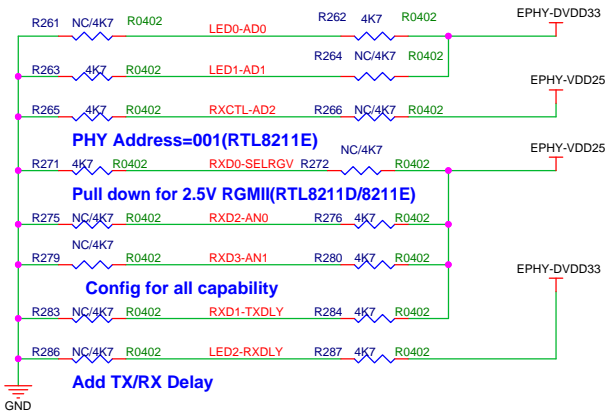
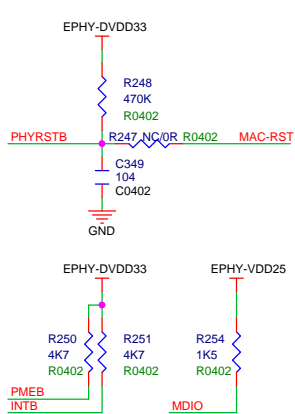
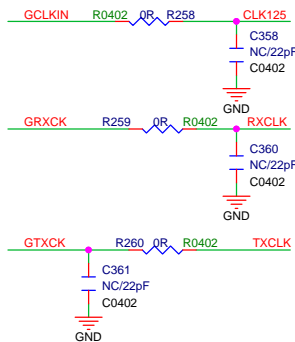

100 ohm

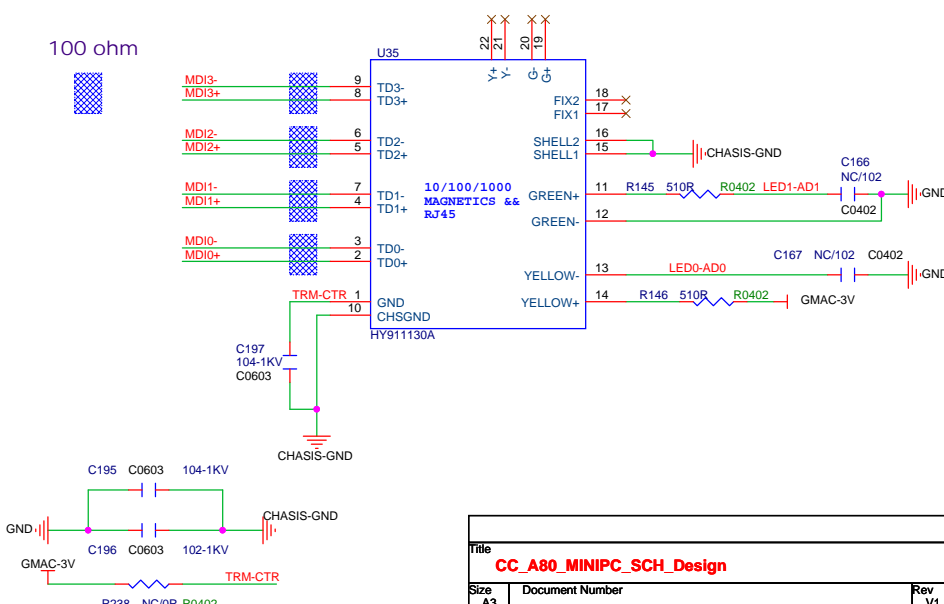

Title <b>CC_A80_MINIPC_SCH_Design</b>		
Size A3	Document Number <a href="http://cubieboard.org">http://cubieboard.org</a>	Rev V1.1
Date:	Sheet 10 of 14	

# CODEC

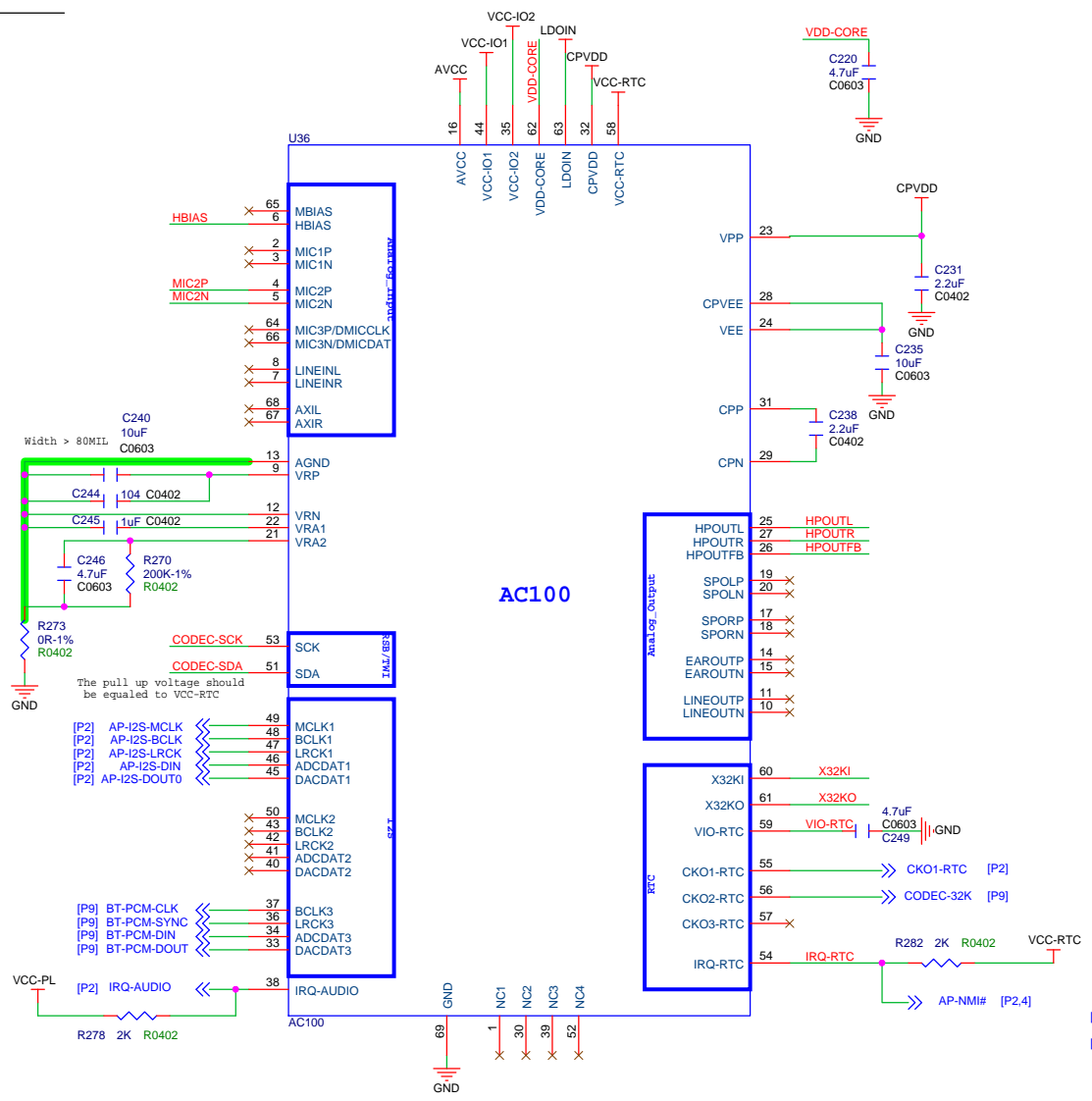

# External MIC IN and Earphone

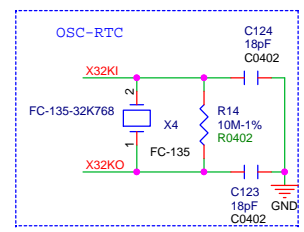
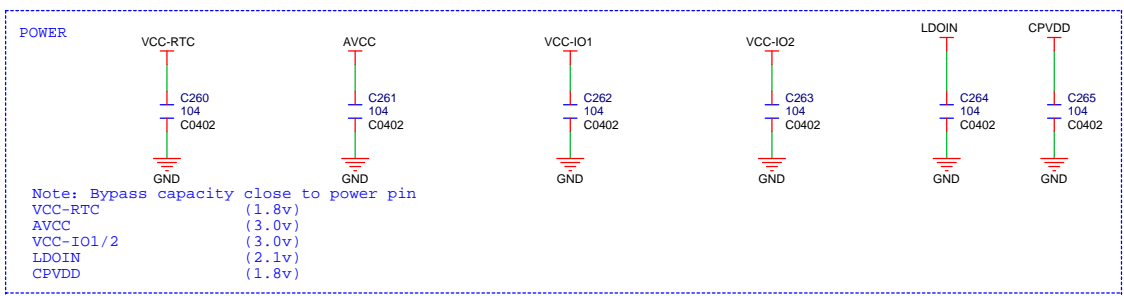
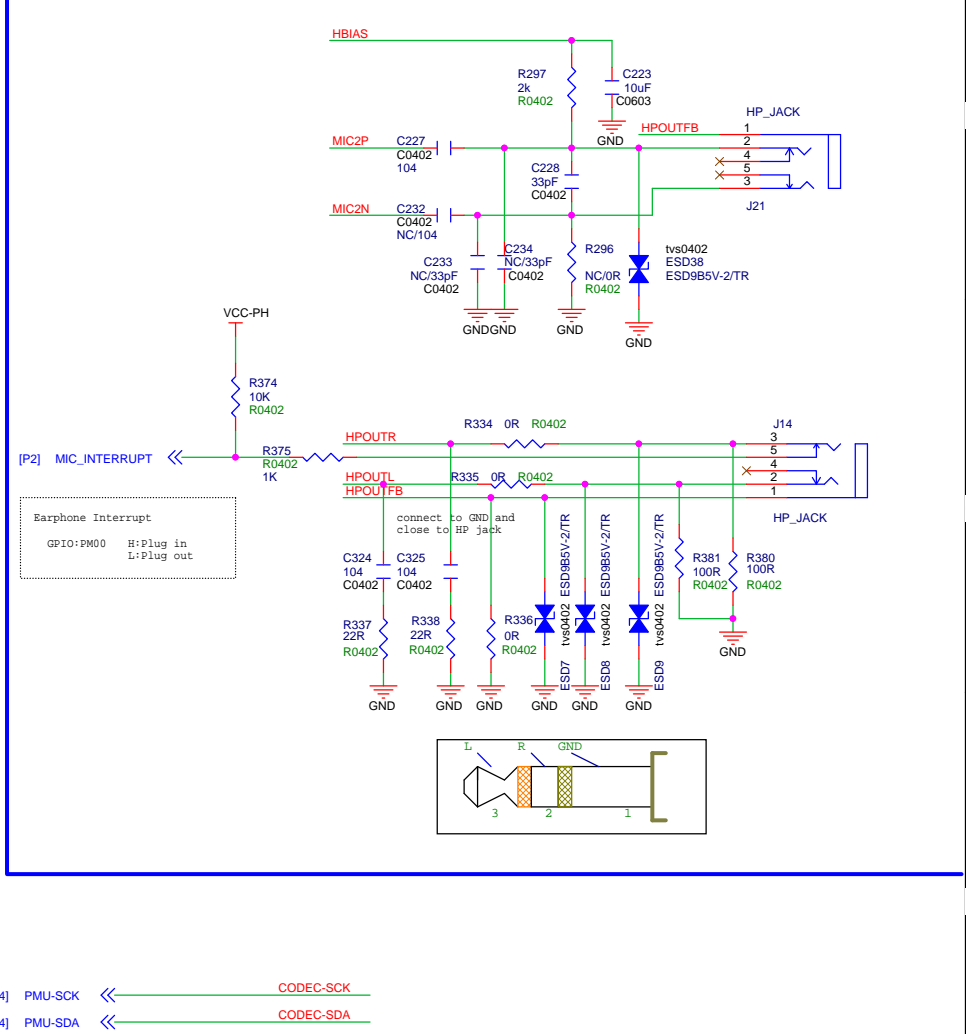

Title		
<b>CC_A80_MINIPC_SCH_Design</b>		
Size	Document Number	Rev
A3	<a href="http://cubieboard.org">http://cubieboard.org</a>	V1.1
Date:	Sheet	11 of 14

# USB Interface

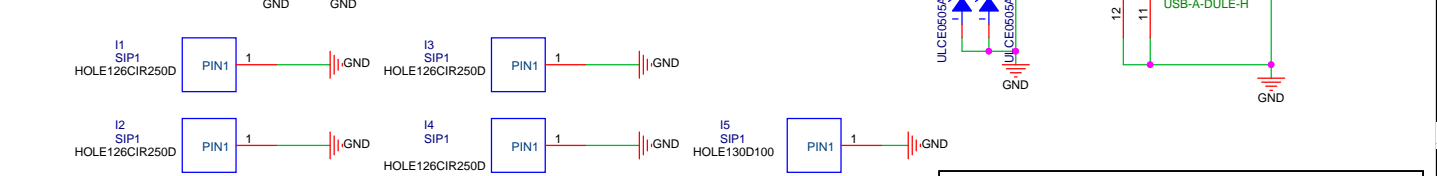
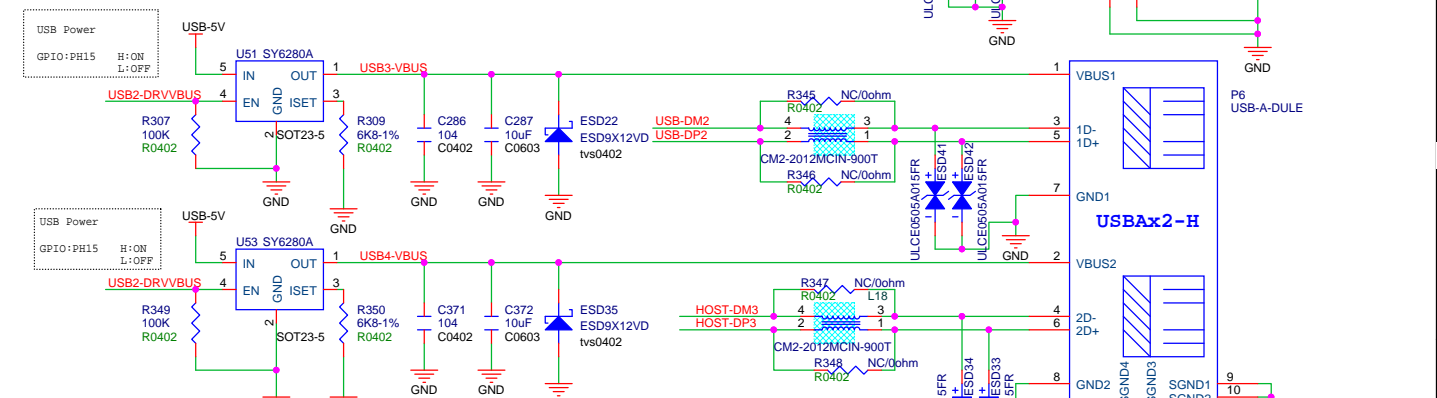
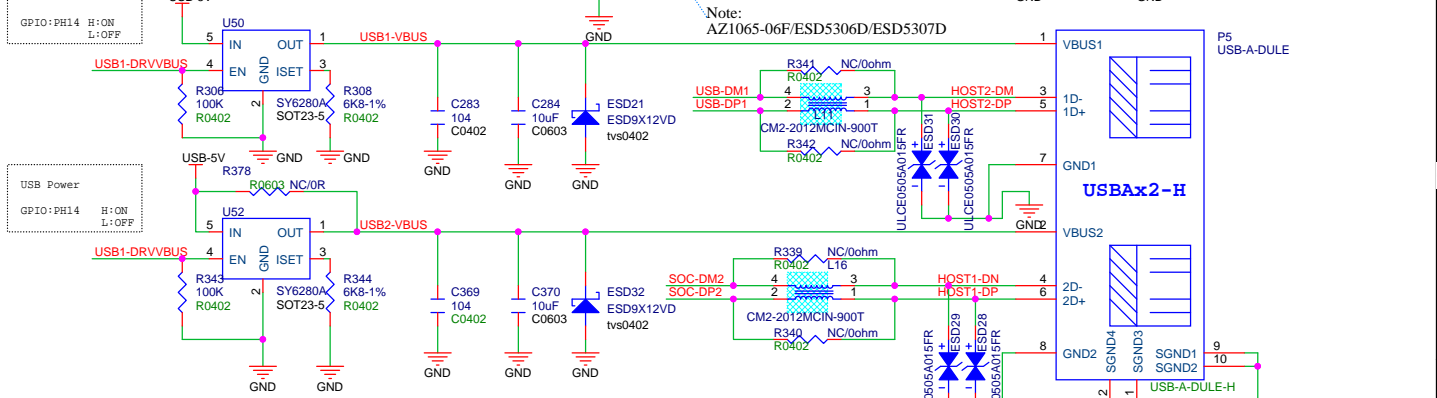
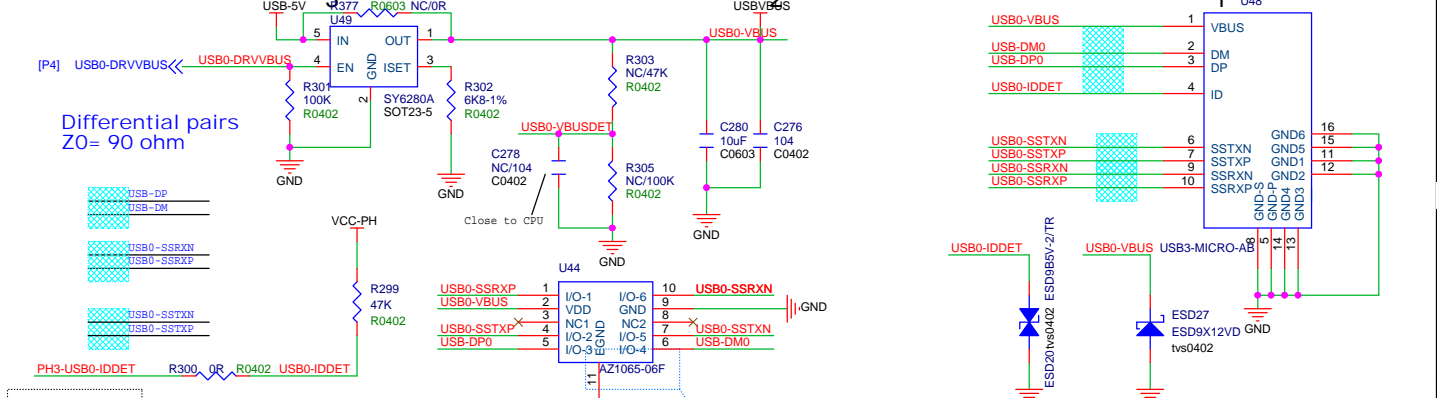
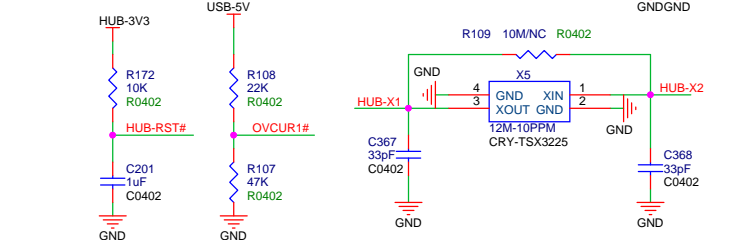
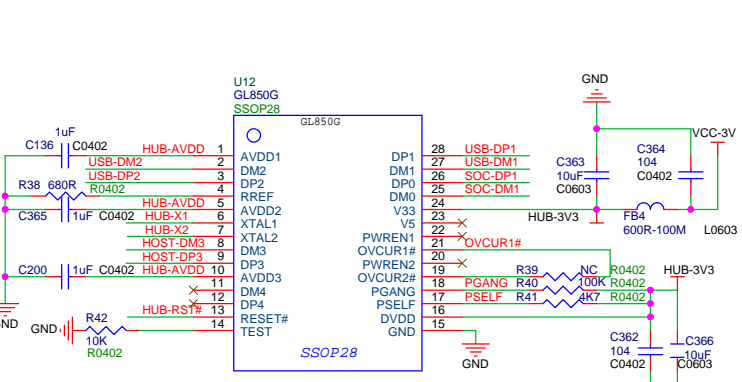
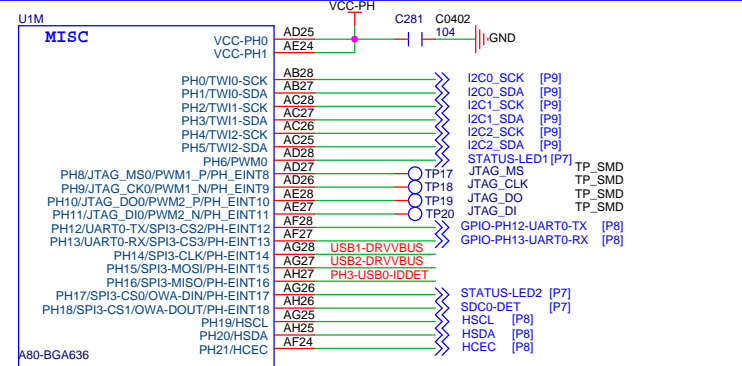
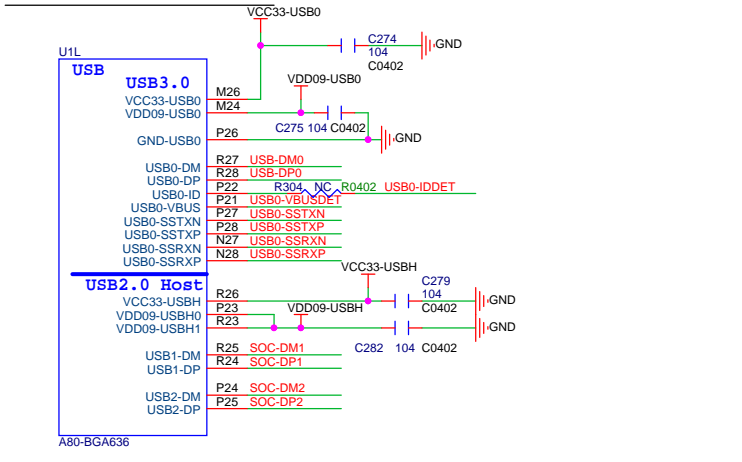

Title <b>CC_A80_MINIPC_SCH_Design</b>		
Size A3	Document Number <a href="http://cubieboard.org">http://cubieboard.org</a>	Rev V1.1
Date:	Sheet	12 of 14