

SDQ14	SDQ14	P[4]	SDQ30	SDQ30	P[4]	SDQS2	SDQS2	P[4]
SDQ9	SDQ9	P[4]	SDQ25	SDQ25	P[4]	SDQS2#	SDQS2#	P[1,4]
SDQ11	SDQ11	P[4]	SDQ27	SDQ27	P[4]	SDQS3	SDQS3	P[4]
SDQ12	SDQ12	P[4]	SDQ28	SDQ28	P[4]	SDQS3#	SDQS3#	P[1,4]
SDQ15	SDQ15	P[4]	SDQ31	SDQ31	P[4]	SDQM2	SDQM2	P[4]
SDQ8	SDQ8	P[4]	SDQ24	SDQ24	P[4]	SDQM3	SDQM3	P[4]
SDQ10	SDQ10	P[4]	SDQ26	SDQ26	P[4]	SDQS0	SDQS0	P[4]
SDQ13	SDQ13	P[4]	SDQ29	SDQ29	P[4]	SDQS0#	SDQS0#	P[1,4]
SDQ7	SDQ7	P[4]	SDQ23	SDQ23	P[4]	SDQS1	SDQS1	P[4]
SDQ0	SDQ0	P[4]	SDQ18	SDQ18	P[4]	SDQS1#	SDQS1#	P[1,4]
SDQ2	SDQ2	P[4]	SDQ16	SDQ16	P[4]	SDQM0	SDQM0	P[4]
SDQ5	SDQ5	P[4]	SDQ18	SDQ18	P[4]	SDQM1	SDQM1	P[4]
			SDQ21	SDQ21	P[4]			
SDQ6	SDQ6	P[4]	SDQ22	SDQ22	P[4]			
SDQ1	SDQ1	P[4]	SDQ17	SDQ17	P[4]			
SDQ3	SDQ3	P[4]	SDQ19	SDQ19	P[4]			
SDQ4	SDQ4	P[4]	SDQ20	SDQ20	P[4]			

Title		
A20-cubieboard-2015-11-24		
Size	Document Number	Rev
A3	<Doc>	V1.0
Date:	Friday, May 13, 2016	Sheet 1 of 11

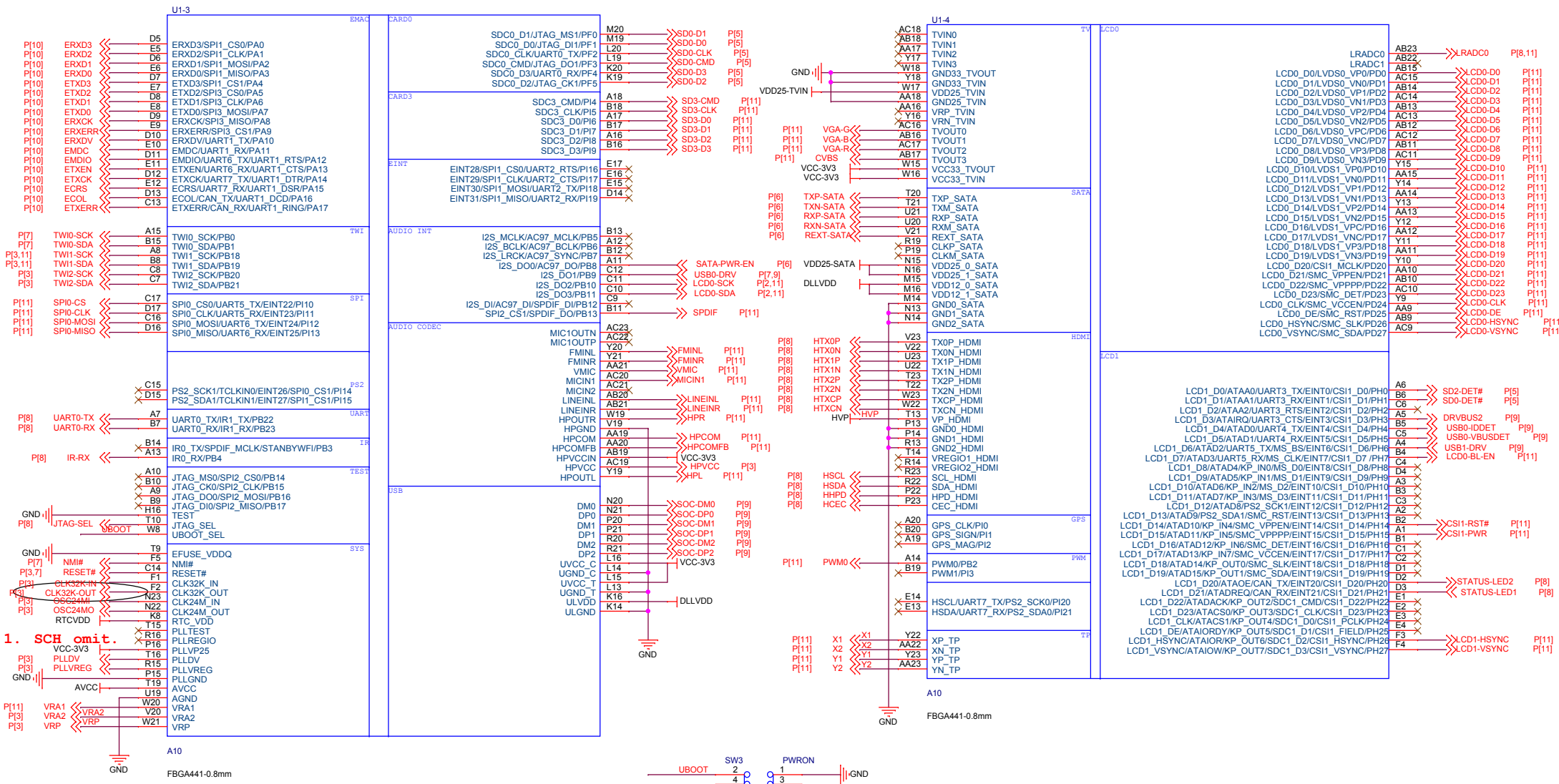

1. SCH omit.

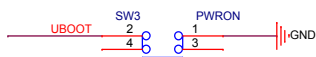

Title		
A20-cubieboard-2015-11-24		
Size	Document Number	Rev
A3	<Doc>	V1.0
Date:	Friday, May 13, 2016	Sheet 2 of 11

DRAM-DLL

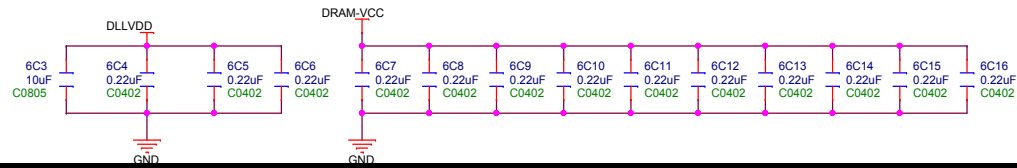

PLL-NAND

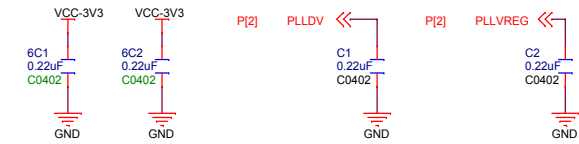

CRYSTAL

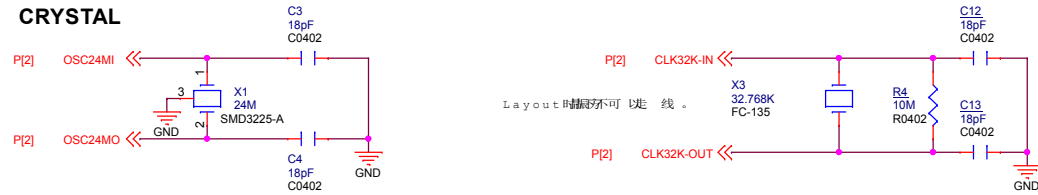

CORE

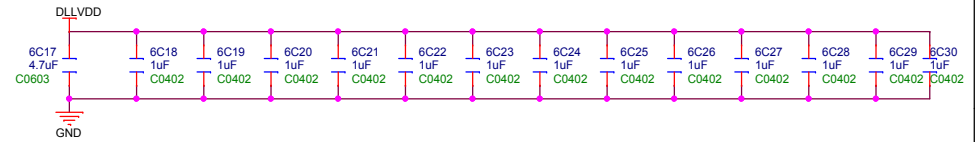

AUDIO-LRADC

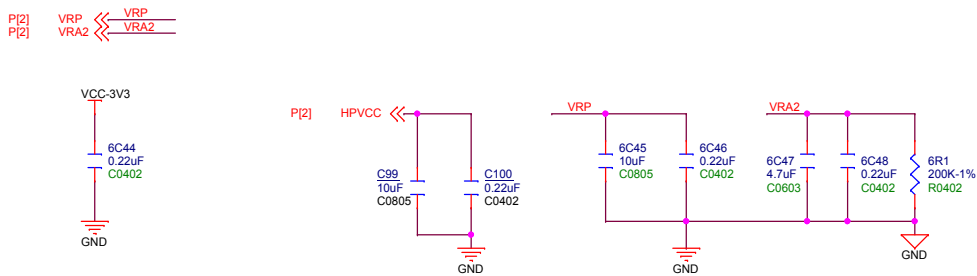

PIO-INTFACE

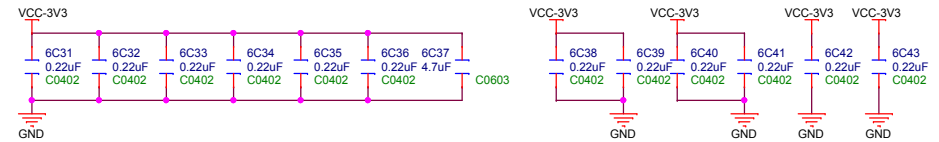

CPU

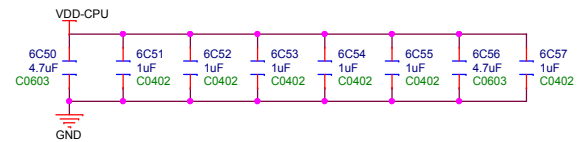

USB-TV-CSI

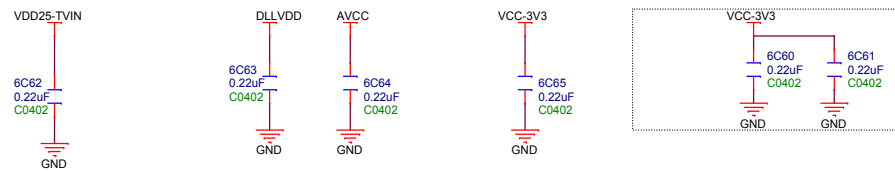

RESET-RTC

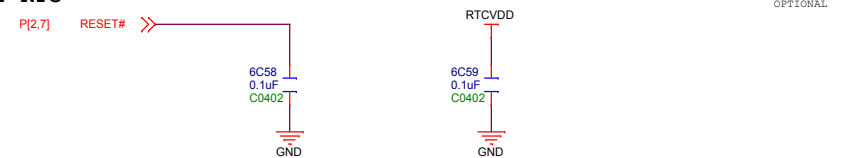

HDMI

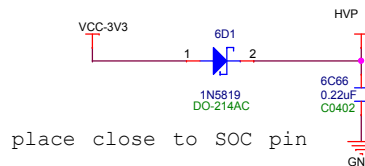

OTHERS

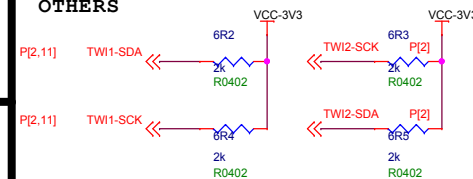

Title		
A20-cubieboard-2015-11-24		
Size	Document Number	Rev
A3	<Doc>	V1.0
Date:	Friday, May 13, 2016	Sheet 3 of 11

DDR3

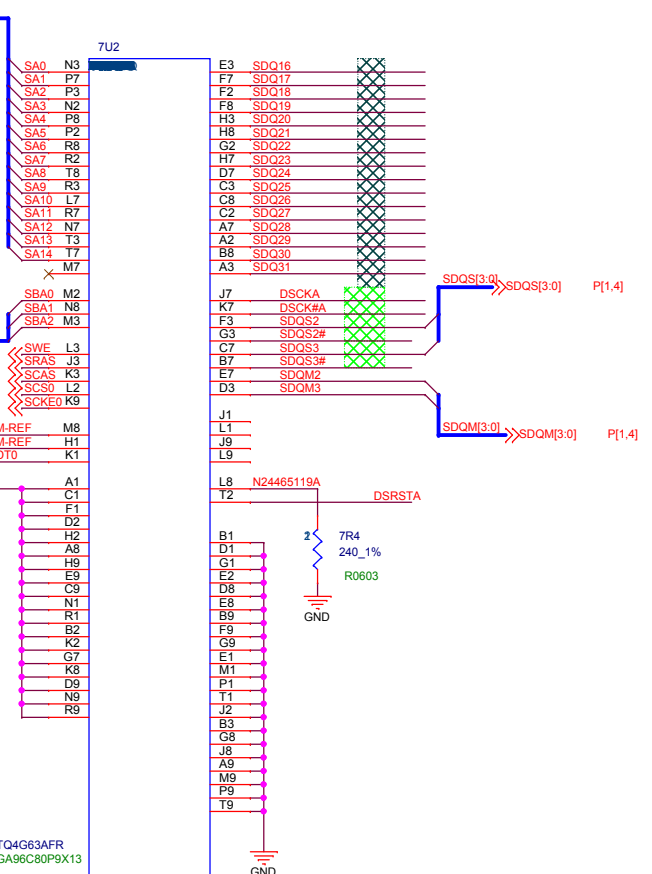
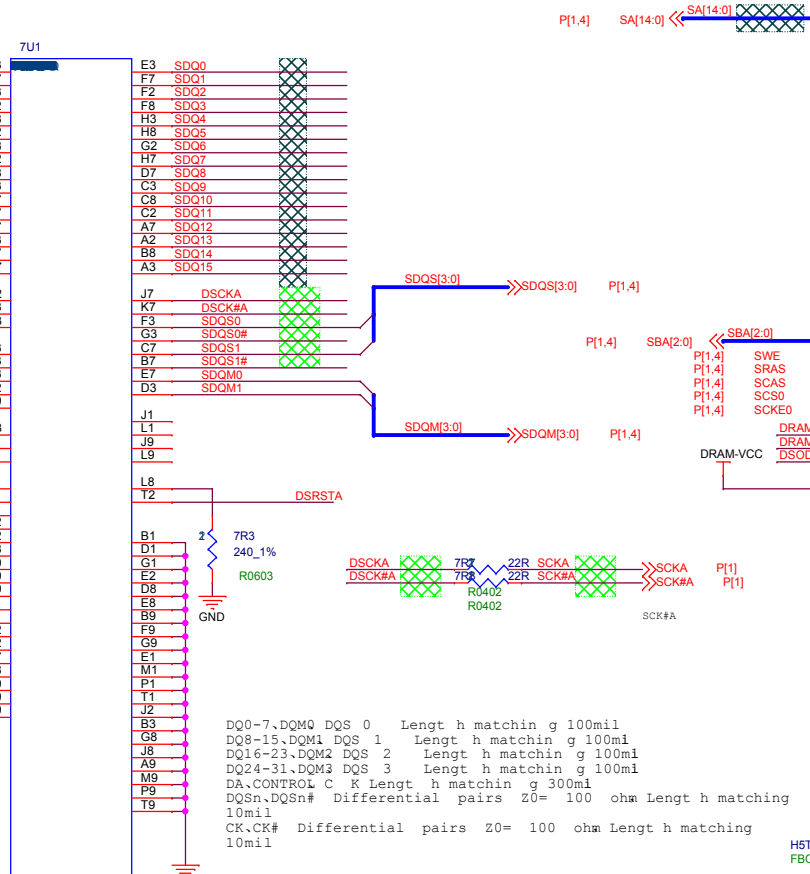
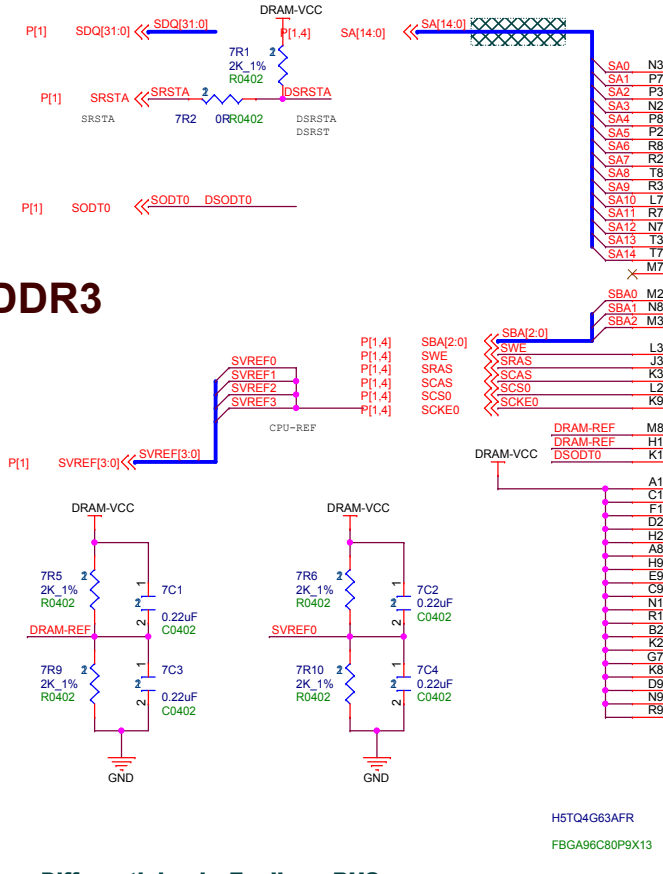

DQ0-7, DQM0 DQS 0 Length h matchin g 100mil
 DQ8-15, DQM1 DQS 1 Length h matchin g 100mi
 DQ16-23, DQM2 DQS 2 Length h matchin g 100mi
 DQ24-31, DQM3 DQS 3 Length h matchin g 100mi
 DA, CONTROL C K Length h matchin g 300mi
 DQSn, DQSn# Differential pairs Z0= 100 ohm Length h matching
 10mil
 CK, CK# Differential pairs Z0= 100 ohm Length h matching
 10mil

Differential pairs Equilong BUS
 Z0= 100 ohm
 Z0= 50 ohm



SDQ14	SDQ14	P[1]	SDQ30	SDQ30	P[1]	SDQS2	SDQS2	P[1]
SDQ9	SDQ9	P[1]	SDQ25	SDQ25	P[1]	SDQS2#	SDQS2#	P[1]
SDQ11	SDQ11	P[1]	SDQ27	SDQ27	P[1]	SDQS3	SDQS3	P[1]
SDQ12	SDQ12	P[1]	SDQ28	SDQ28	P[1]	SDQS3#	SDQS3#	P[1]
SDQ15	SDQ15	P[1]	SDQ31	SDQ31	P[1]	SDQM2	SDQM2	P[1]
SDQ8	SDQ8	P[1]	SDQ24	SDQ24	P[1]	SDQM3	SDQM3	P[1]
SDQ10	SDQ10	P[1]	SDQ26	SDQ26	P[1]	SDQS0	SDQS0	P[1]
SDQ13	SDQ13	P[1]	SDQ29	SDQ29	P[1]	SDQS0#	SDQS0#	P[1]
SDQ7	SDQ7	P[1]	SDQ23	SDQ23	P[1]	SDQS1	SDQS1	P[1]
SDQ0	SDQ0	P[1]	SDQ16	SDQ16	P[1]	SDQS1#	SDQS1#	P[1]
SDQ2	SDQ2	P[1]	SDQ18	SDQ18	P[1]	SDQM0	SDQM0	P[1]
SDQ5	SDQ5	P[1]	SDQ21	SDQ21	P[1]	SDQM1	SDQM1	P[1]
SDQ6	SDQ6	P[1]	SDQ22	SDQ22	P[1]			
SDQ1	SDQ1	P[1]	SDQ17	SDQ17	P[1]			
SDQ3	SDQ3	P[1]	SDQ19	SDQ19	P[1]			
SDQ4	SDQ4	P[1]	SDQ20	SDQ20	P[1]			

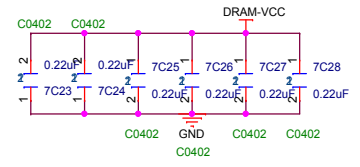
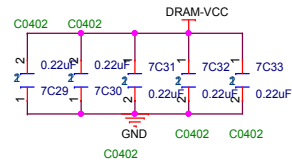
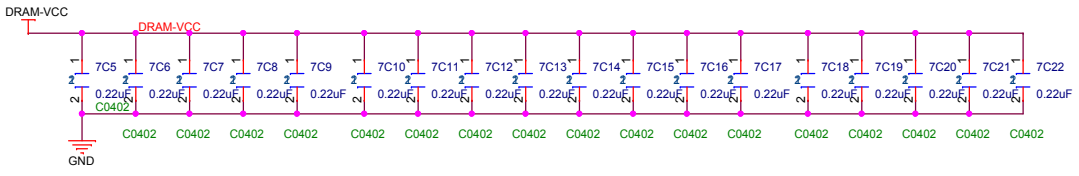

CARD0



eMMC FLASH

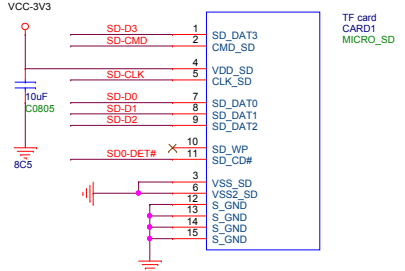
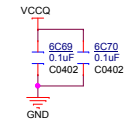
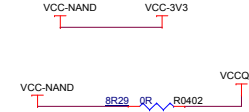
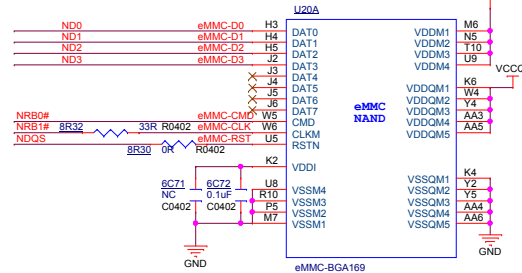

CARD2

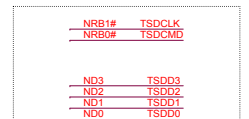
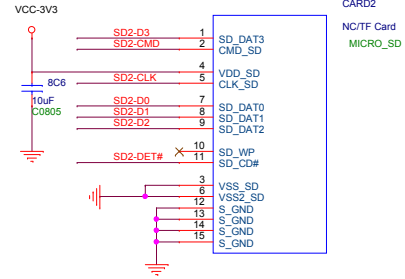
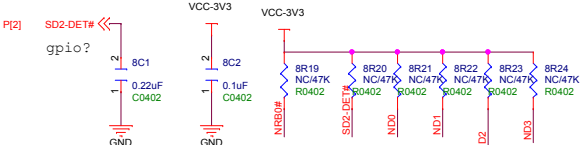
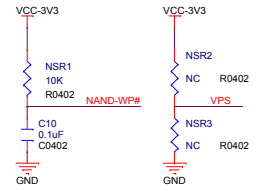
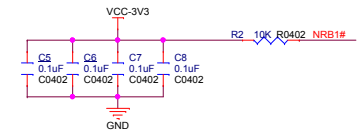
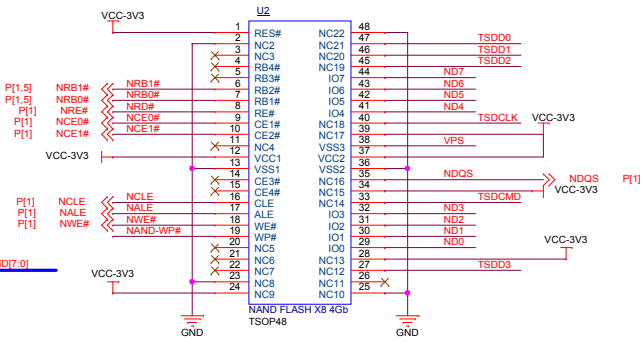
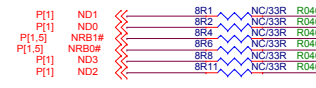

Title			A20-cubieboard-2015-11-24		
Size	Document	Number	Rev V1.0		
Custom-Doc					
Date:	Friday, May 13, 2016	Sheet	5	of	11

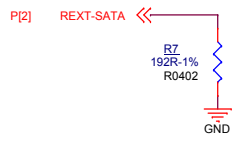

BESIDE CPU

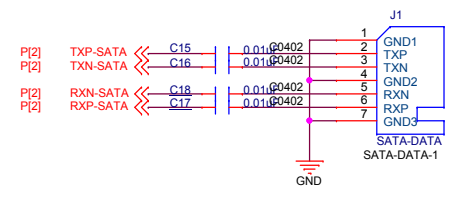
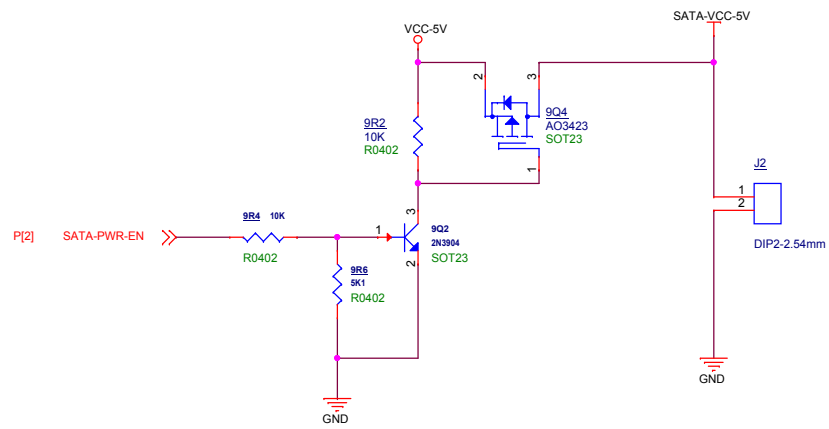

Title		
A20-cubieboard-2015-11-24		
Size	Document Number	Rev
A3	<Doc>	V1.0
Date:	Friday, May 13, 2016	Sheet 6 of 11

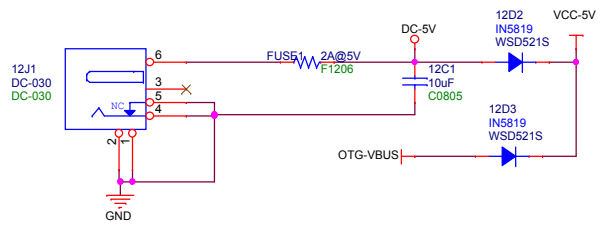

1.5V FOR DDR3

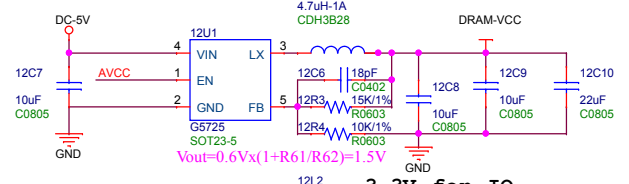

3.3V for IO

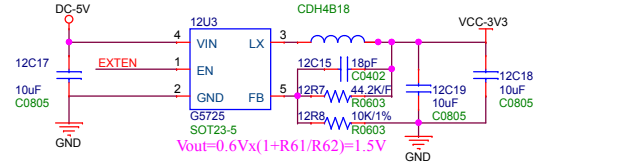

SATA-VCC 2.5V for SATA

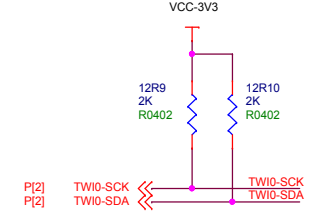
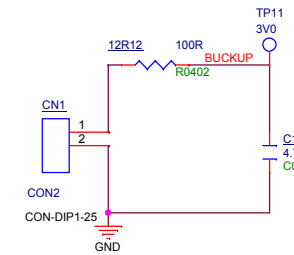
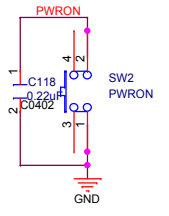
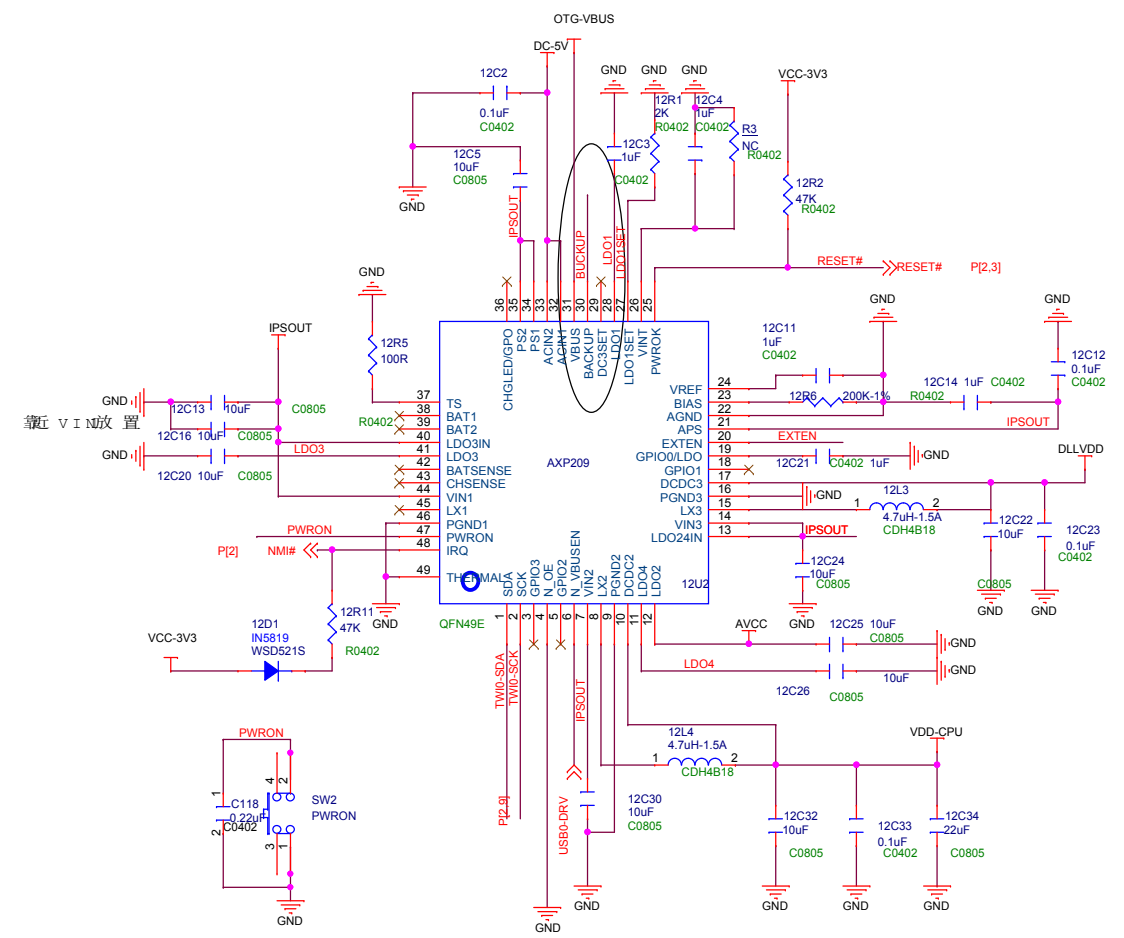
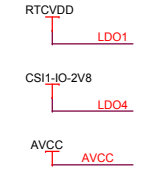
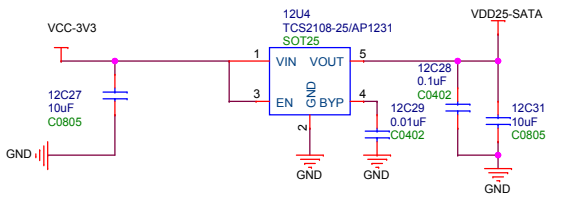

Title		
A20-cubieboard-2015-11-24		
Size	Document Number	Rev
A3	<Doc>	V1.0
Date:	Friday, May 13, 2016	Sheet 7 of 11

HDMI

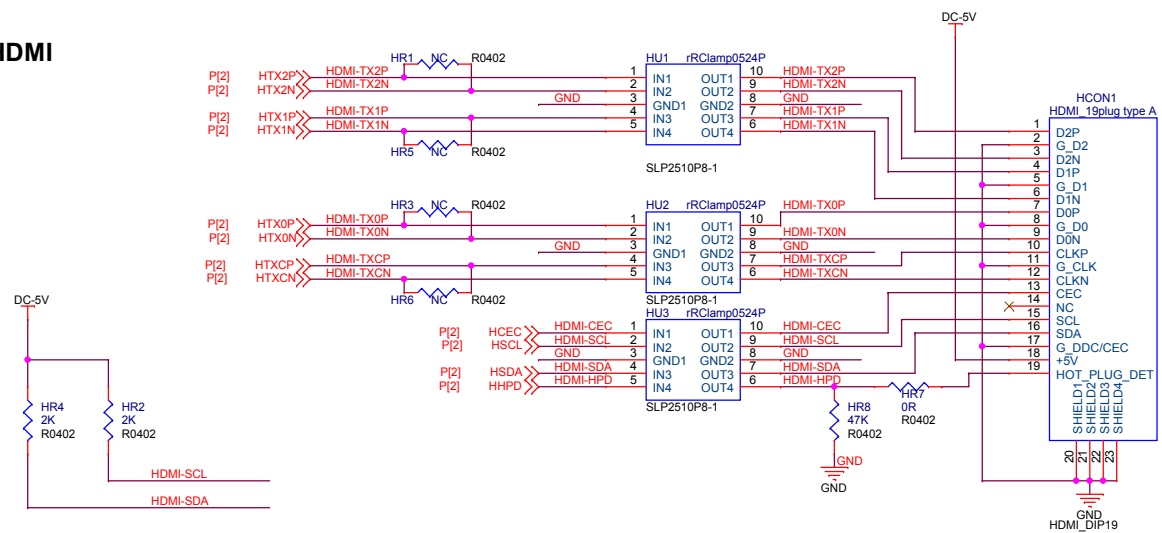

LED

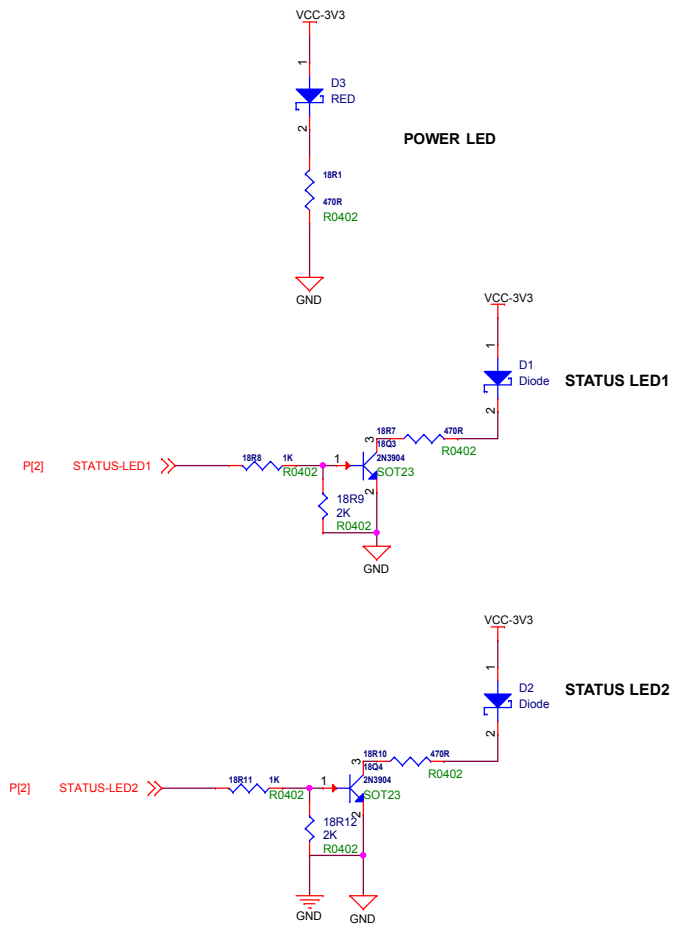

IR MODULE

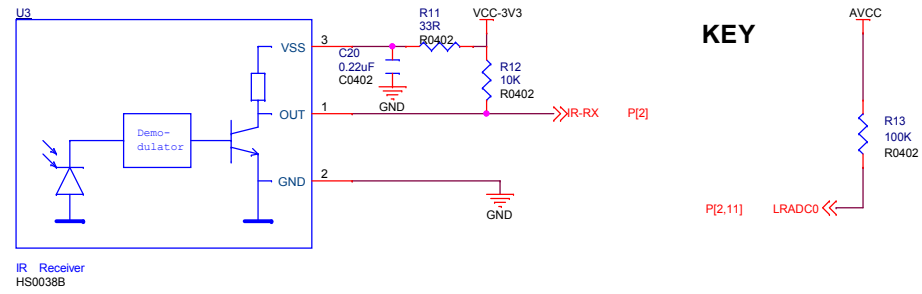

DEBUG

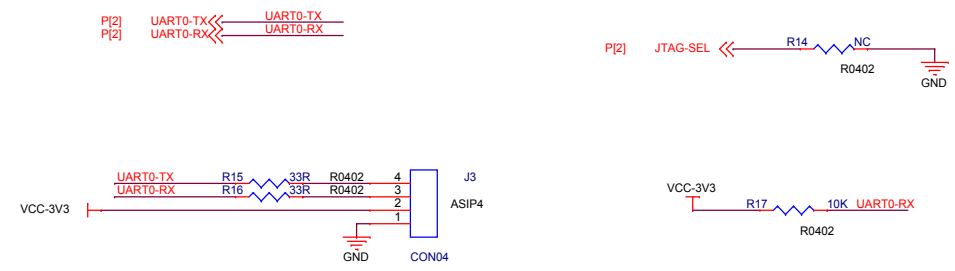

Title		
A20-cubieboard-2015-11-24		
Size	Document Number	Rev
A3	<Doc>	V1.0
Date:	Friday, May 13, 2016	Sheet 8 of 11

USB HOSTx 2

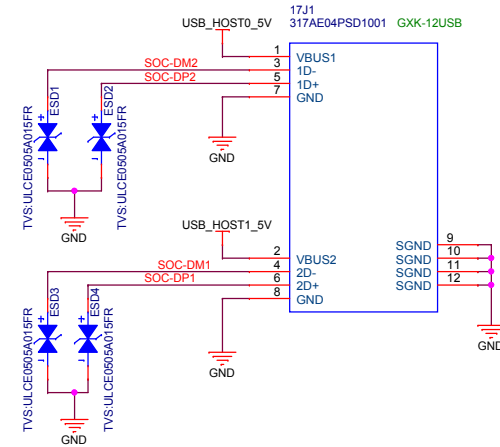
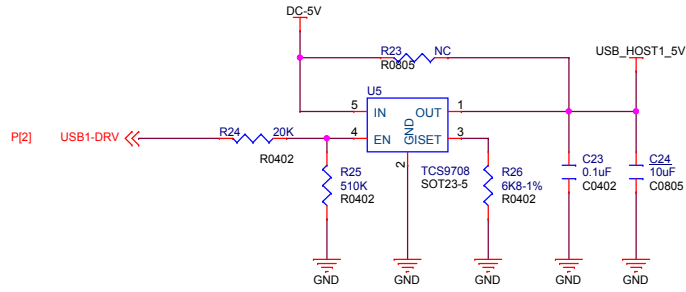
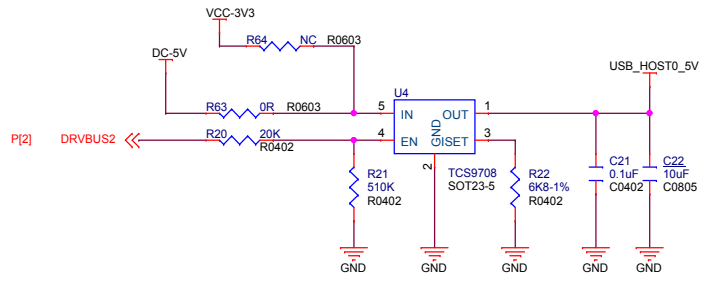

OTG

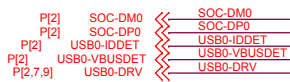
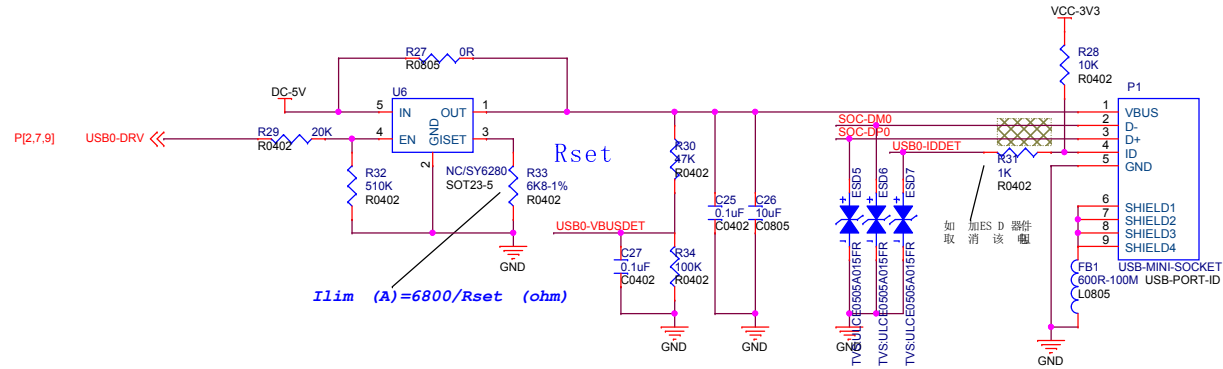

Title		
A20-cubieboard-2015-11-24		
Size	Document Number	Rev
A3	<Doc>	V1.0
Date:	Friday, May 13, 2016	Sheet 9 of 11

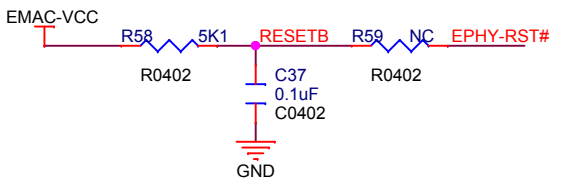
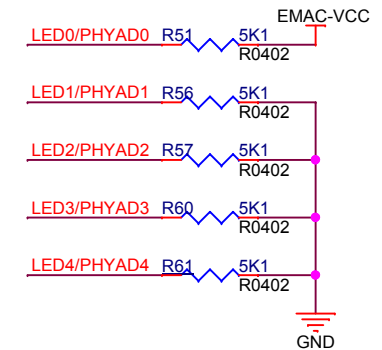
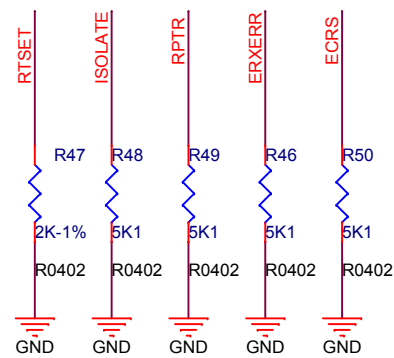
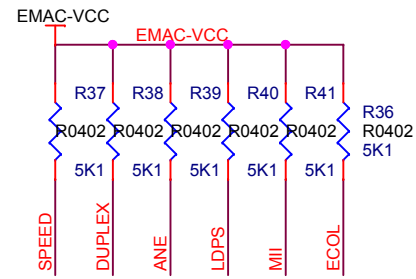
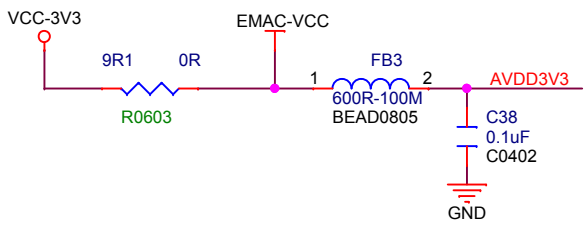
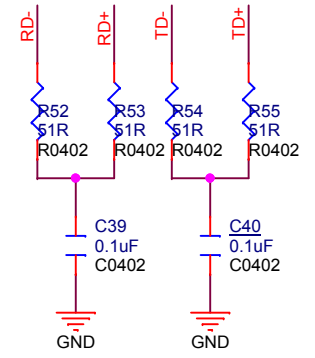
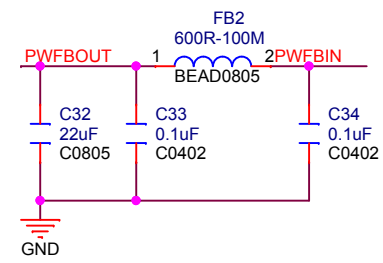
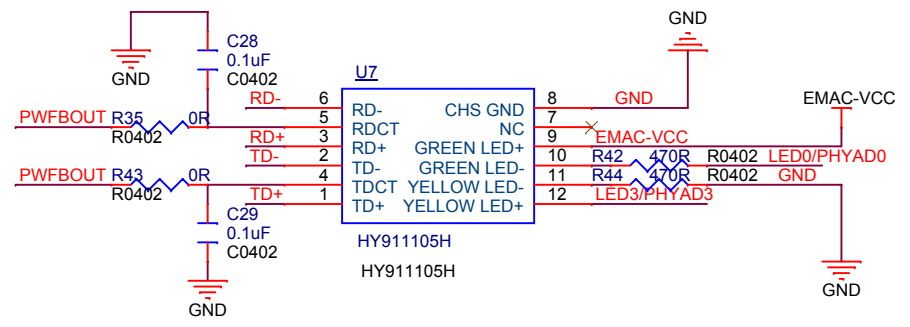
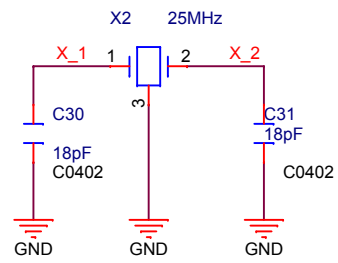
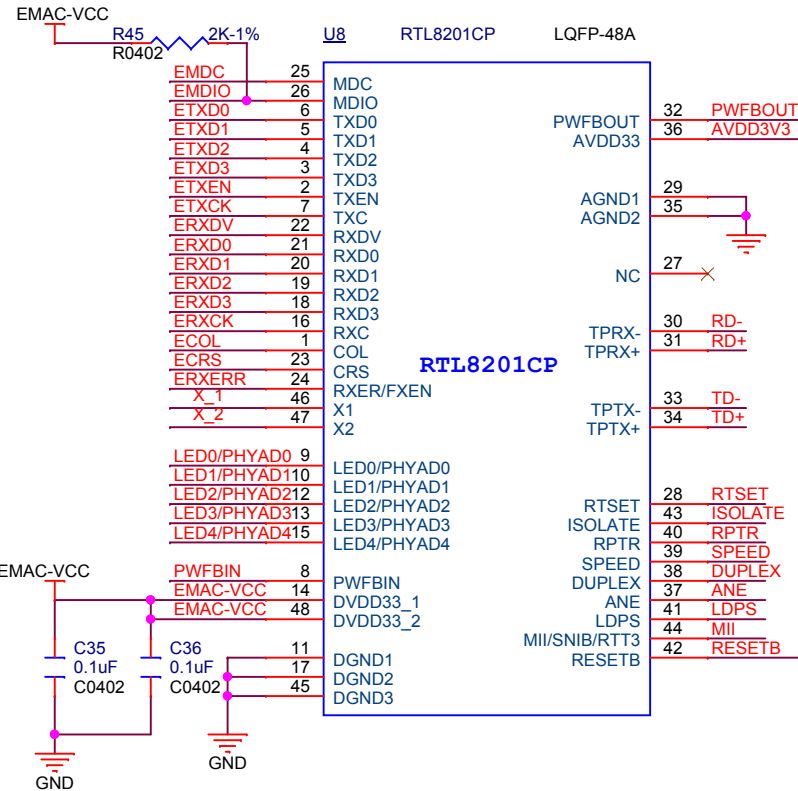
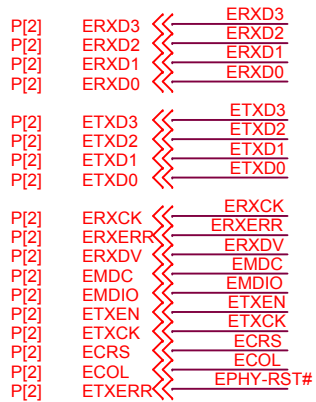

Title		
A20-cubieboard-2015-11-24		
Size	Document Number	Rev
A4	EMAC	V1.0
Date:	Friday, May 13, 2016	Sheet 10 of 11

Extention interface

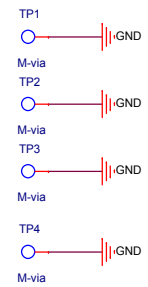
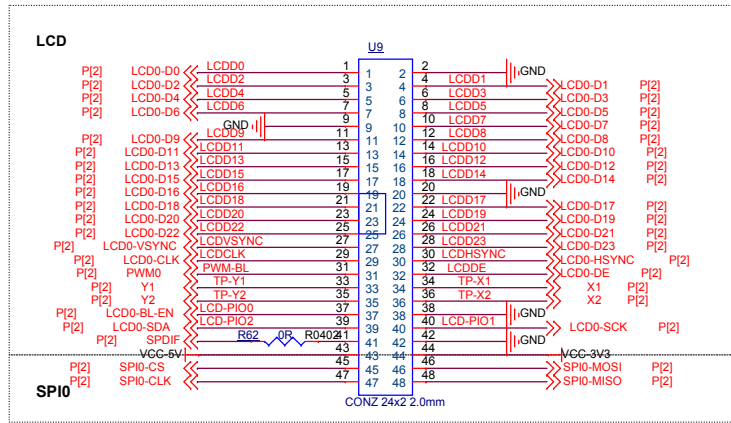

CSI1/TS

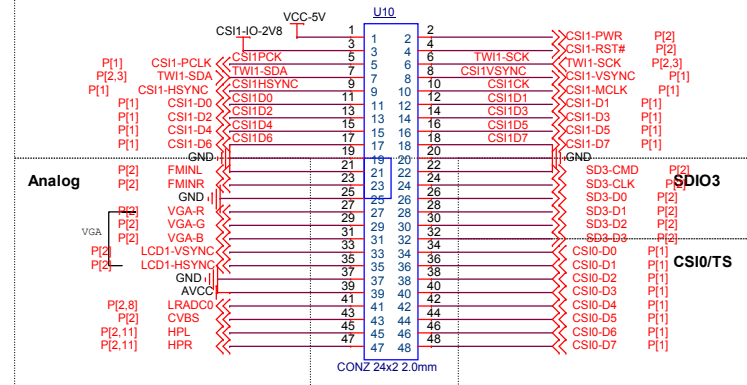

Line-In

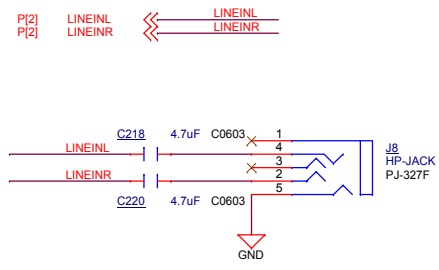

MIC

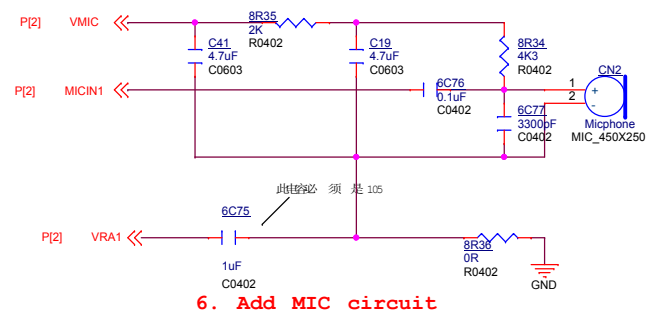

Head Phone & Speaker

