

BLOCK

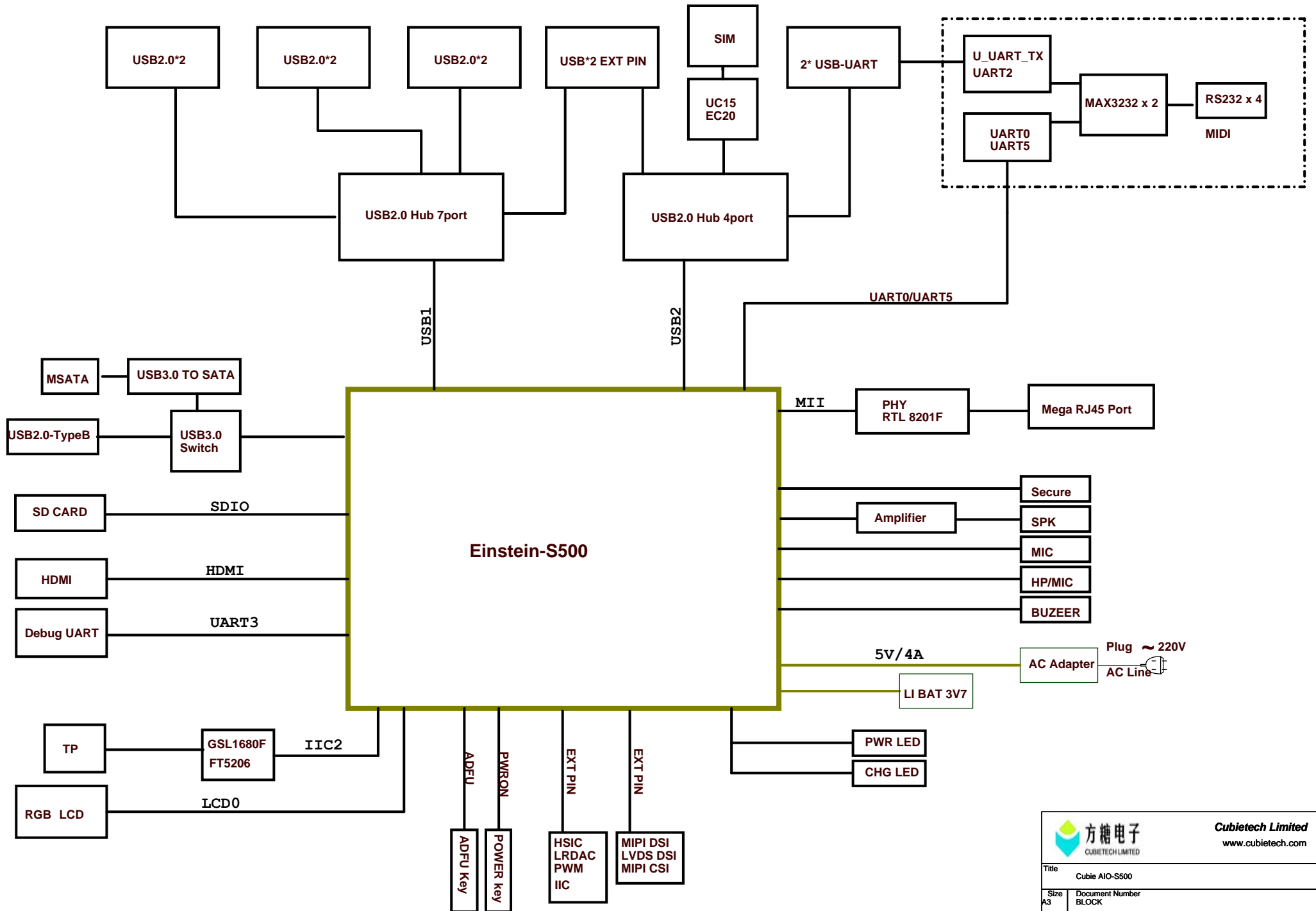

POWER TREE

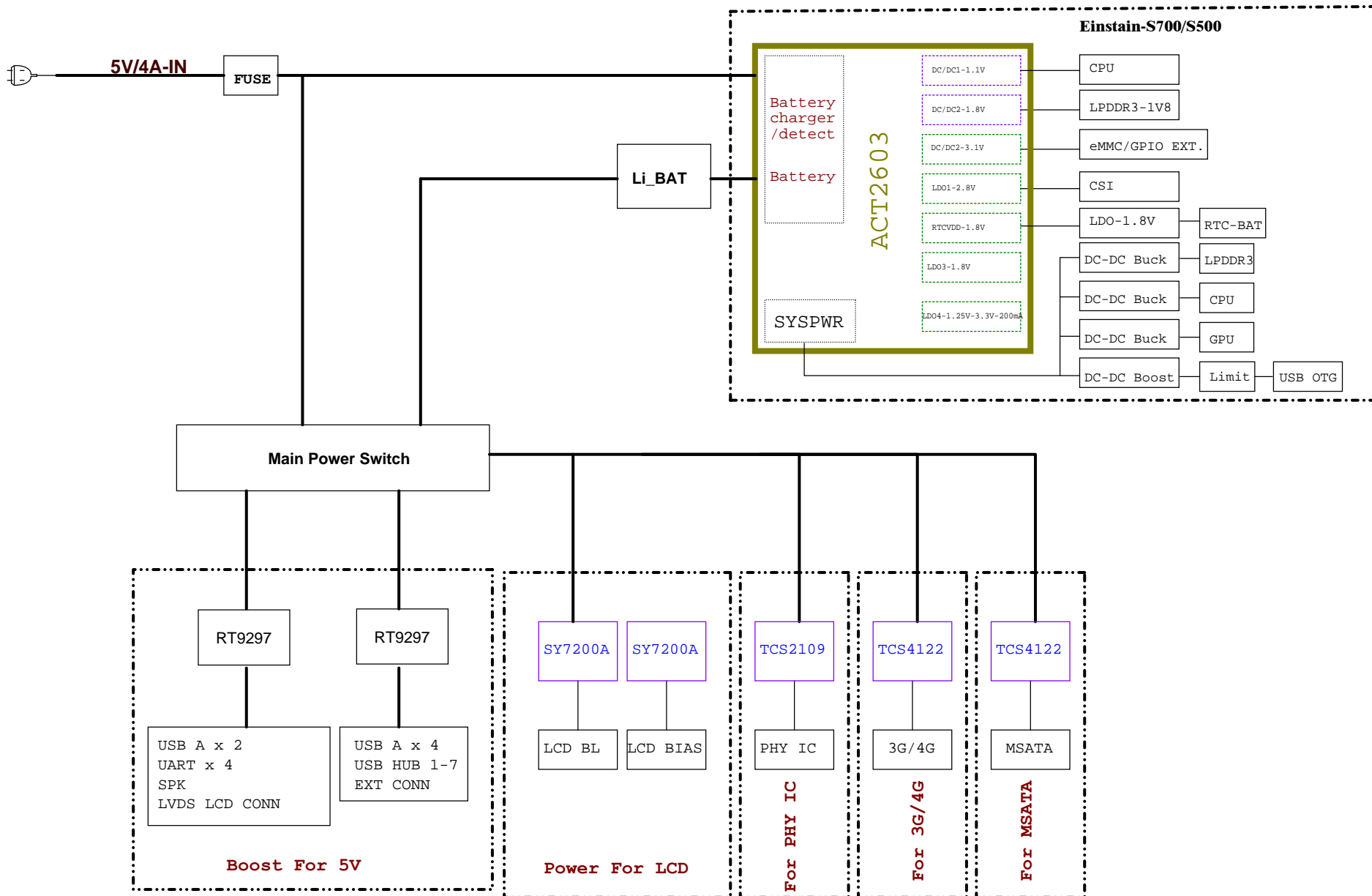

POWER SUPPLY

DC-IN & DC-DC

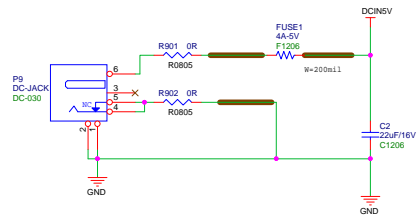

BAT

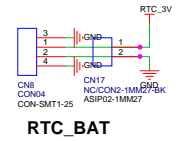
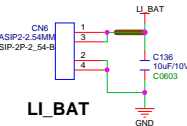

LED

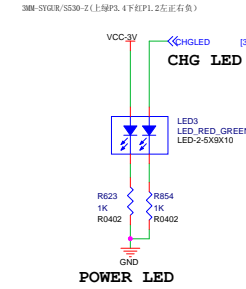

Current Limited EN

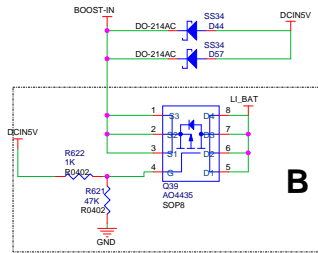
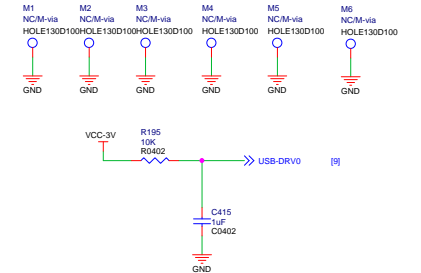

A FOR NO BATTERY
B FOR BATTERY

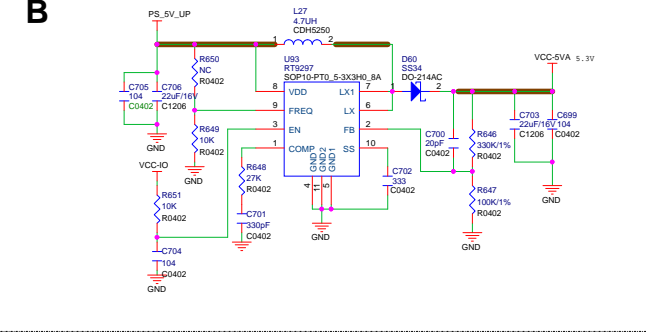
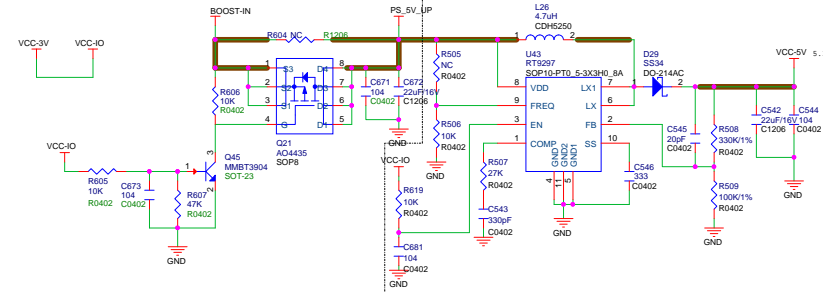
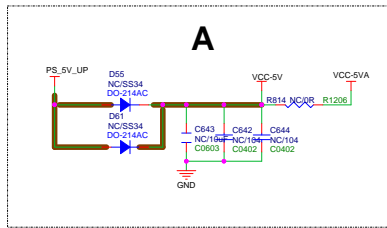

LCD

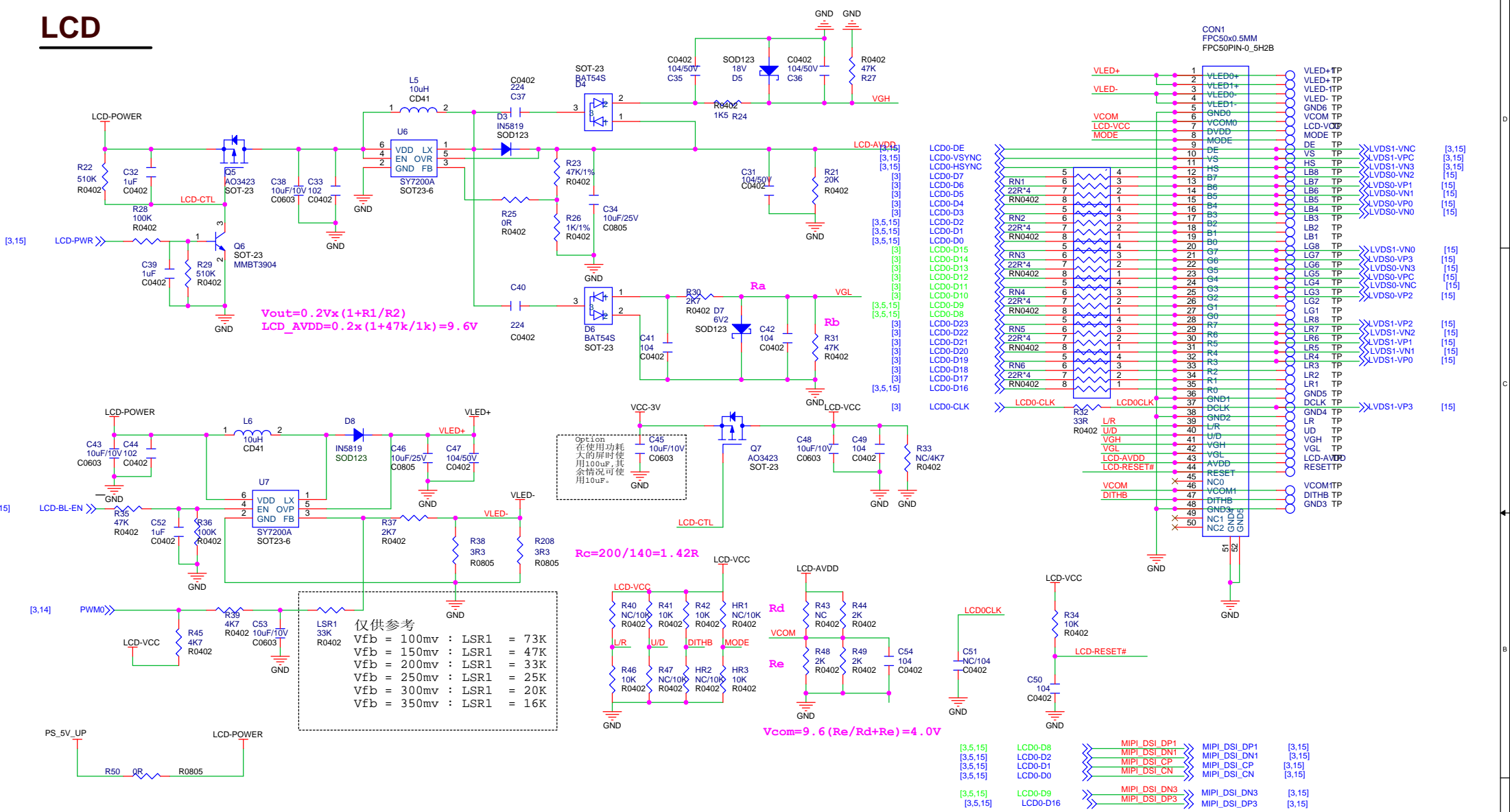



方糖电子
CUBIETECH LIMITED

Cubietech Limited
www.cubietech.com

| | | |
|-------------------------------------|----------------------|----------|
| Title: Cubie AIO-S500 | | |
| Size: A3 | Document Number: LCD | Rev: V10 |
| Date: Wednesday, September 06, 2017 | Sheet: 5 | of: 15 |

TP

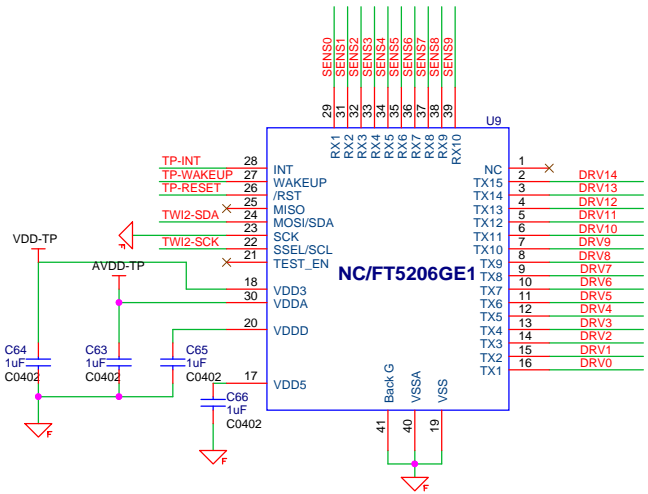
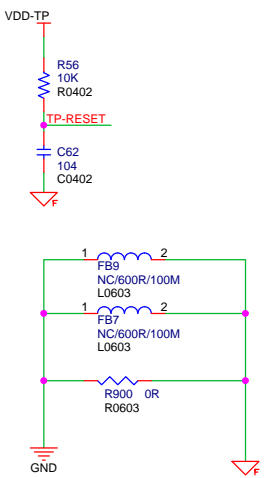
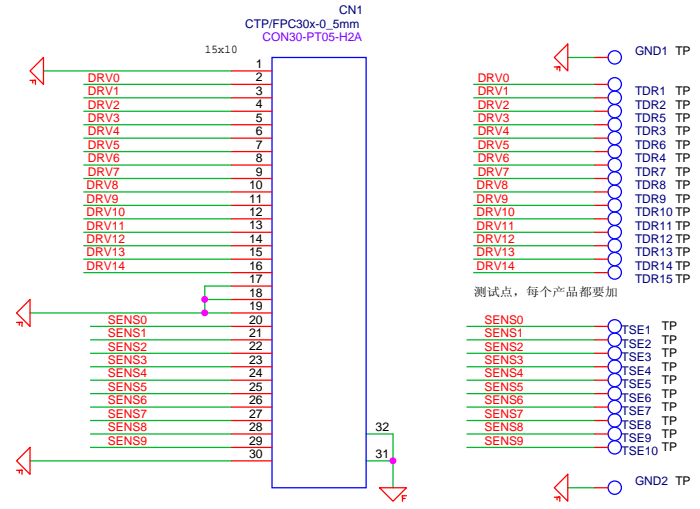
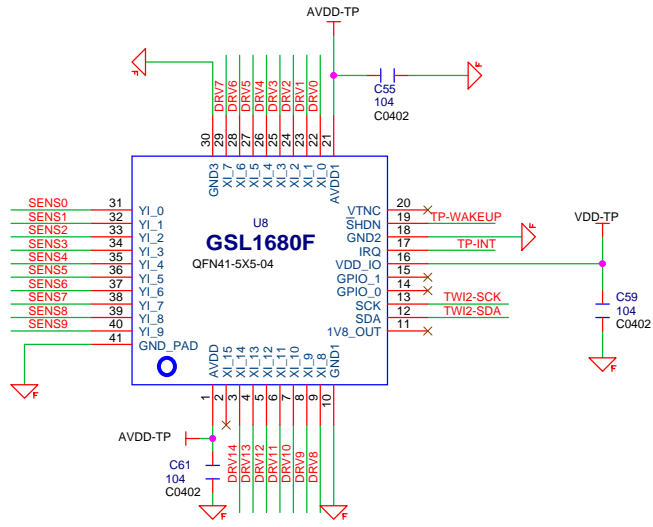
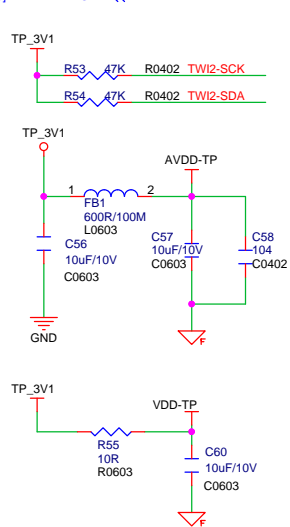

HDMI

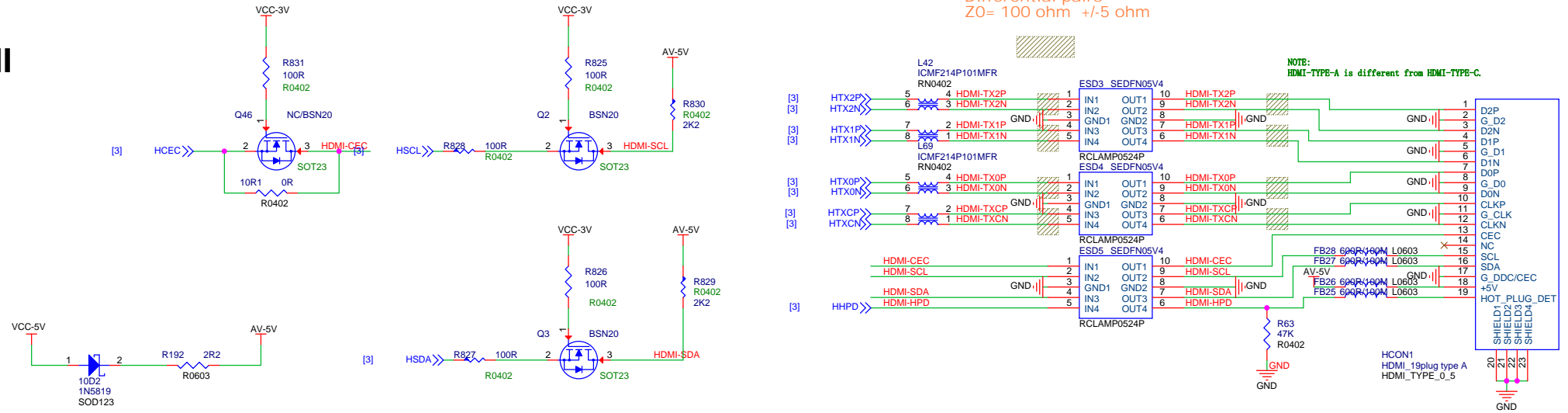

CARD0

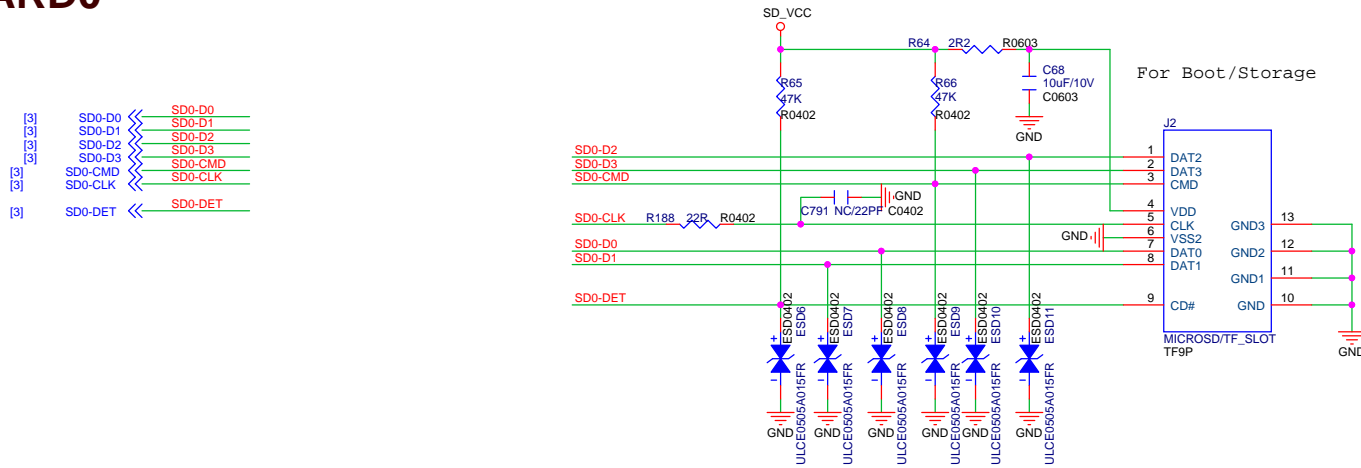

KEY

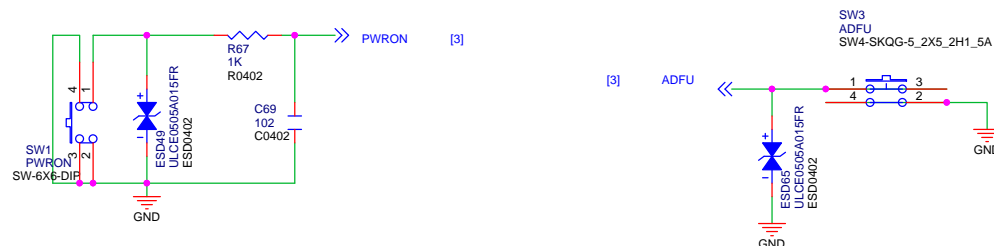

| | | | |
|--|------------------------|---|--|
|  方糖电子 CUBIETECH LIMITED | | Cubietech Limited www.cubietech.com | |
| Title Cubie AIO-S500 | | | |
| Size A3 | Document Number | Rev V10 | |
| Date: Wednesday, September 06, 2017 Sheet 7 of 15 | | | |

UART x 4

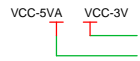

USB TO UART1

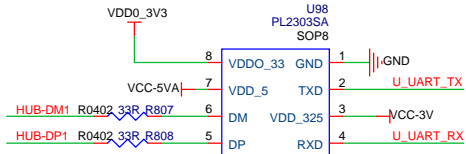
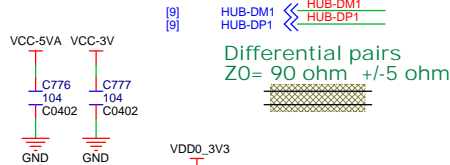

MIDI JACK

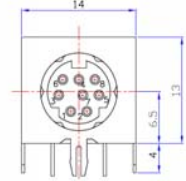

PCB板安装孔图

MDC-8-03

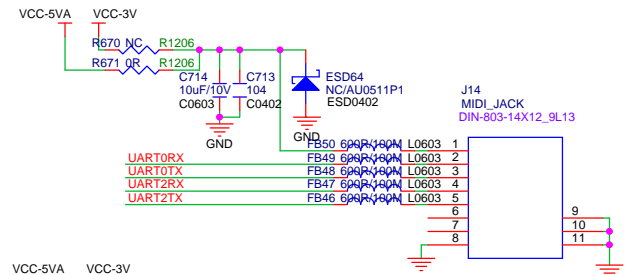

USB TO UART2

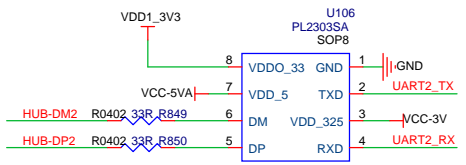
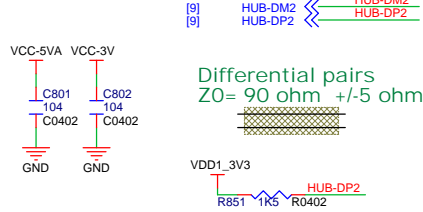

RS232_1

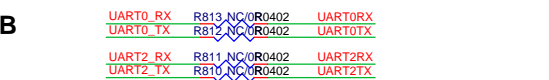
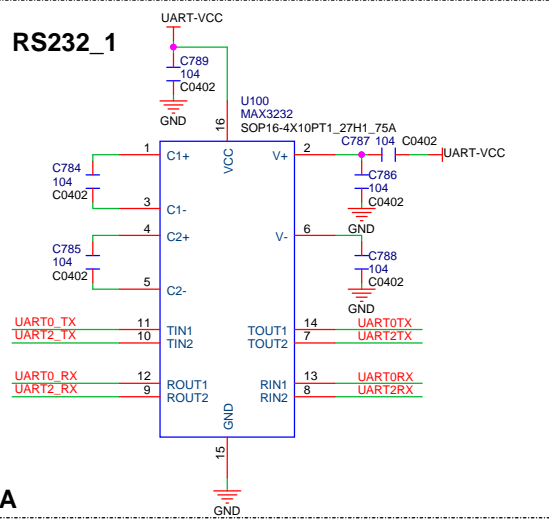

RS232_2

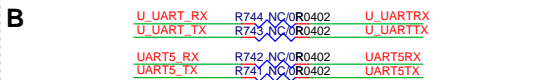
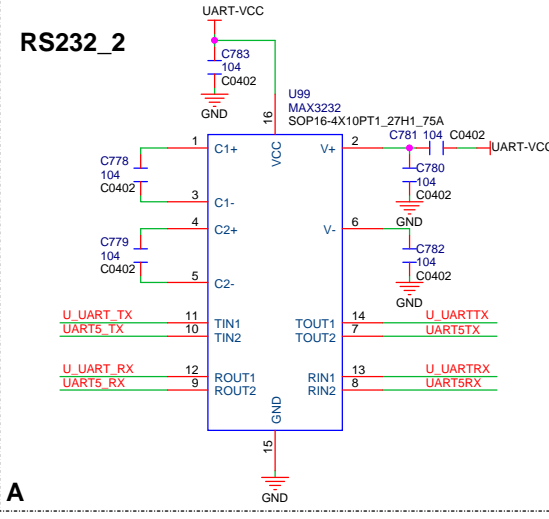

UART3

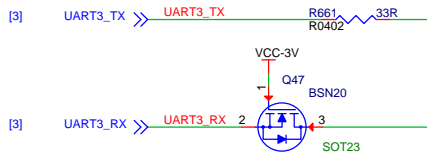

DEBUG

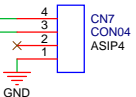

| | | |
|-------------------------------------|----------------------------------|--|
| | | Cubietech Limited www.cubietech.com |
| Title: Cubie AIO-S500 | | |
| Size: A3 | Document Number: UART(RS232) x 4 | Rev: V10 |
| Date: Wednesday, September 06, 2017 | Sheet: 10 | of 15 |

4G MODULE

RF Microstrip
Z0= 90 ohm

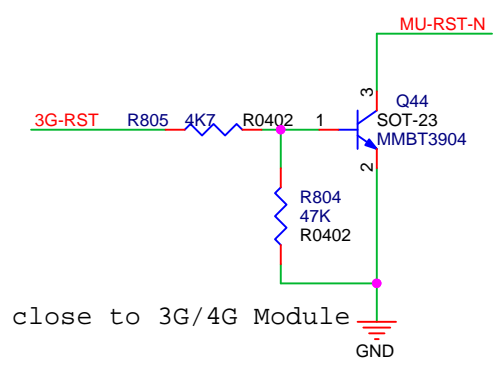
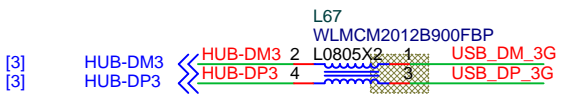

close to 3G/4G Module

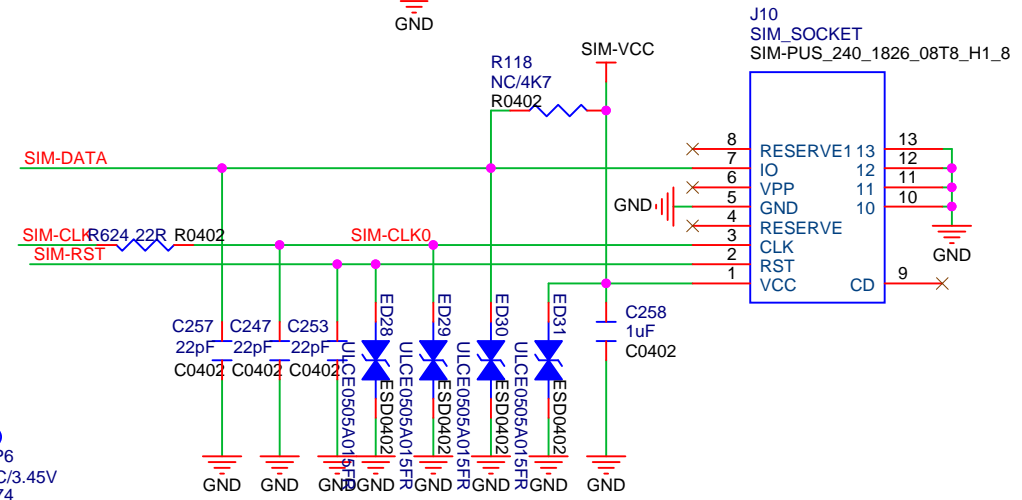
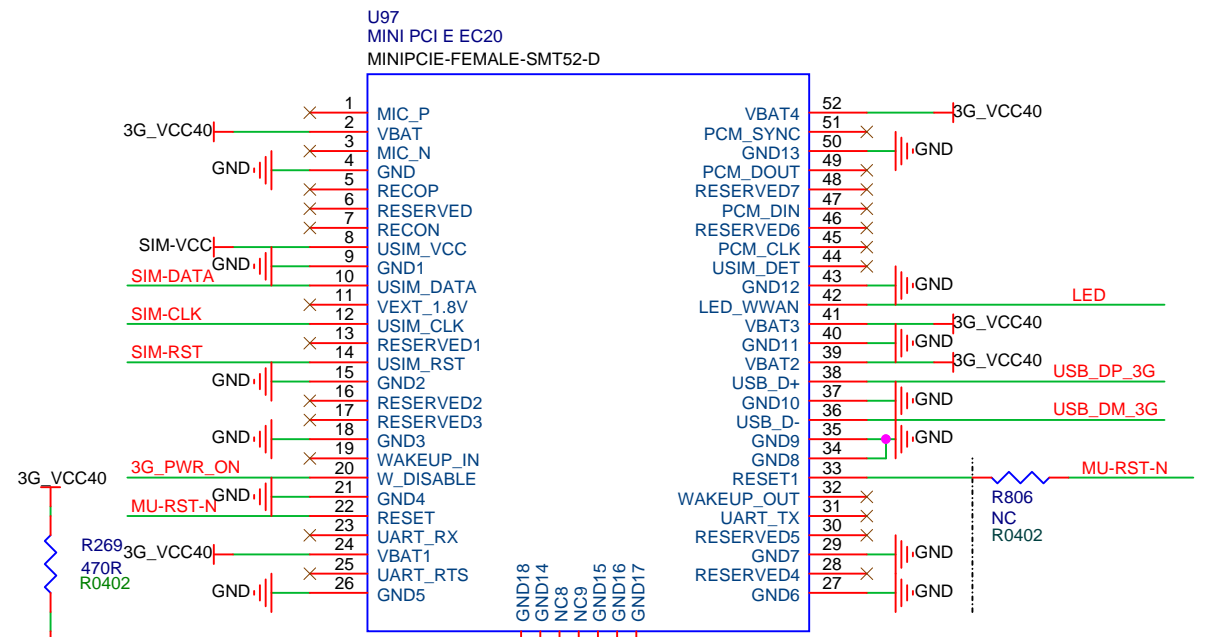
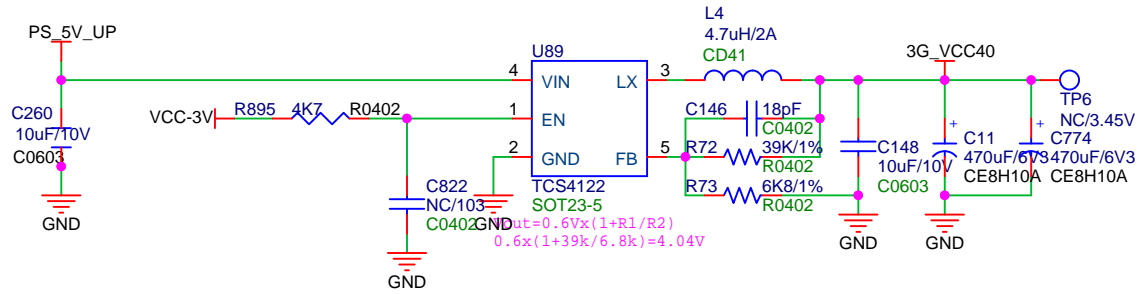



方糖电子
CUBIETECH LIMITED

Cubietech Limited
www.cubietech.com

| | | |
|----------------|-------------------------------|----------------|
| Title | | |
| Cubie AIO-S500 | | |
| Size | Document Number | Rev |
| A4 | 3G/4G | V10 |
| Date: | Wednesday, September 06, 2017 | Sheet 11 of 15 |

Head Phone

- [3] HPL << HPL
- [3] HPR << HPR
- [3,13,14] VMIC << VMICEXT
- [3,13,14] MICIN1 << MICIN1

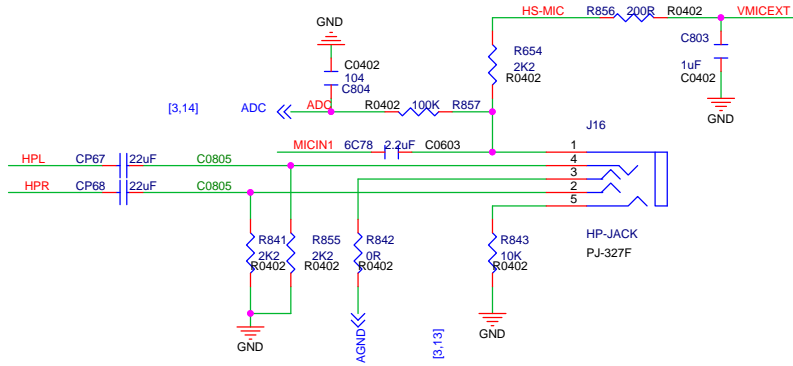

BUZEER

- [3,13] BUZZR_EN << BUZZR_EN

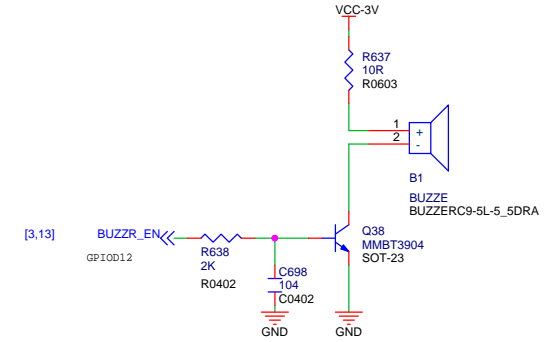

Microphone

- [3,13,14] VMIC << VMIC
- [3,13,14] MICIN1 << MICIN1
- [3,13] AGND << AGND

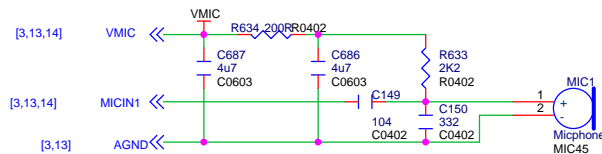

IR MODULE

- [3,14] IR-RX << IR-RX

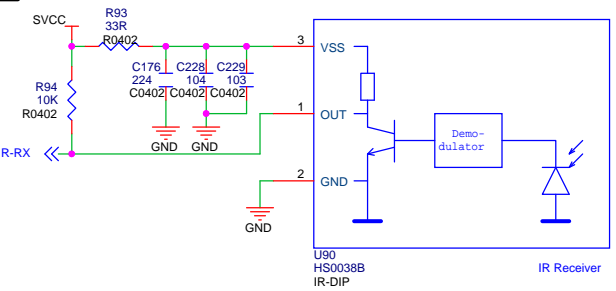

SPK

- [3,14] PA-SHDN# << PA-SHDN#

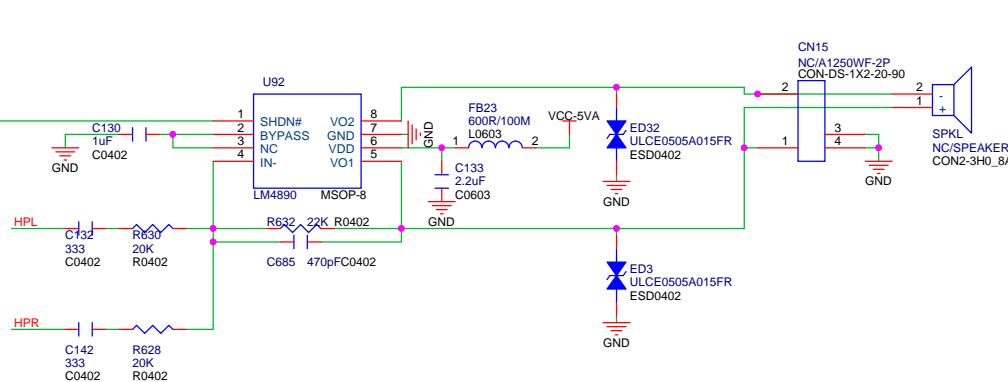

| | | | |
|--|--------------------------------|---|--|
|  方糖电子 CUBIETECH LIMITED | | Cubietech Limited www.cubietech.com | |
| Title: Cubie AIO-S500 | | | |
| Size A3 | Document Number HP/MIC/SPK/BEE | Rev V10 | |
| Date: Wednesday, September 06, 2017 | Sheet 13 | of 15 | |

USB-B

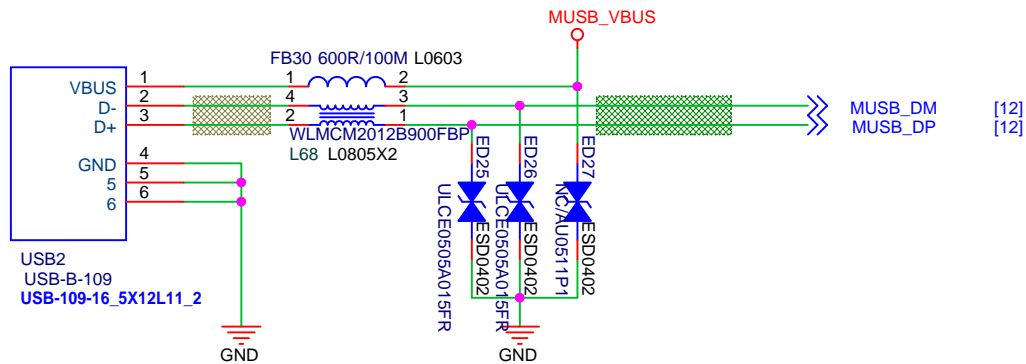

Secure

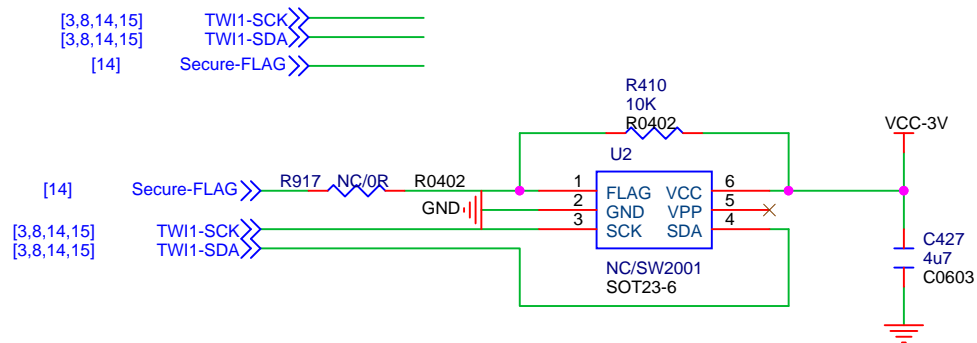

Extention interface

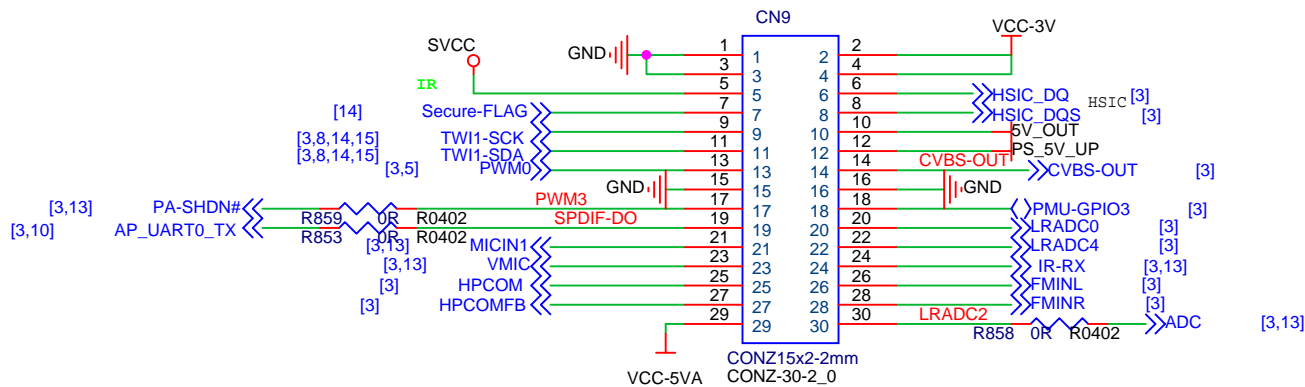

FAN

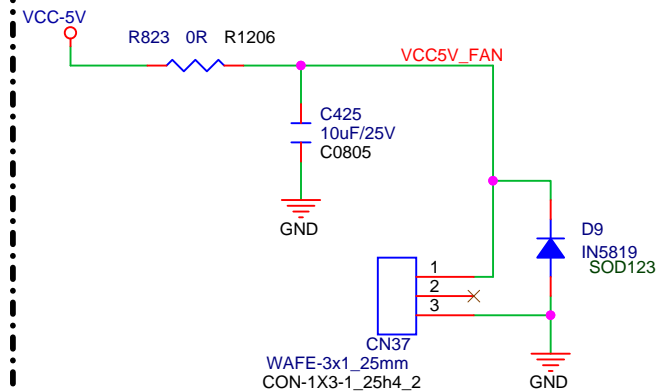

Cubietech Limited
www.cubietech.com

| | | |
|--|------------------------------------|------------|
| Title Cubie AIO-S500 | | |
| Size A4 | Document Number EXT.GPIO/Secure | Rev V10 |
| Date: Wednesday, September 06, 2017 | Sheet 14 | of 15 |

MIPI / LVDS LCD

[3,8,14,15] TWI1-SDA
 [3,8,14,15] TWI1-SCK
 [3,5,15] LCD-PWR
 [3,5,15] LCD-BL-EN

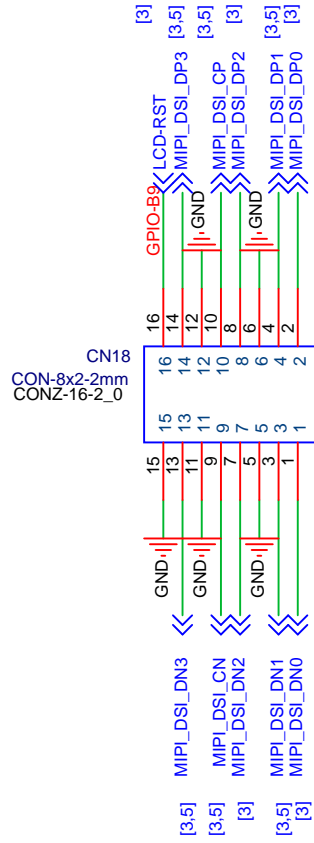
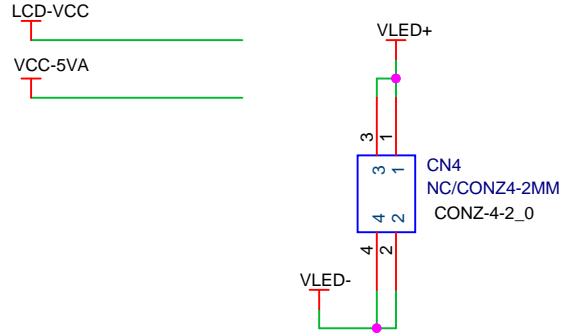

Differential pairs
 $Z_0 = 100 \text{ ohm} \pm 5 \text{ ohm}$

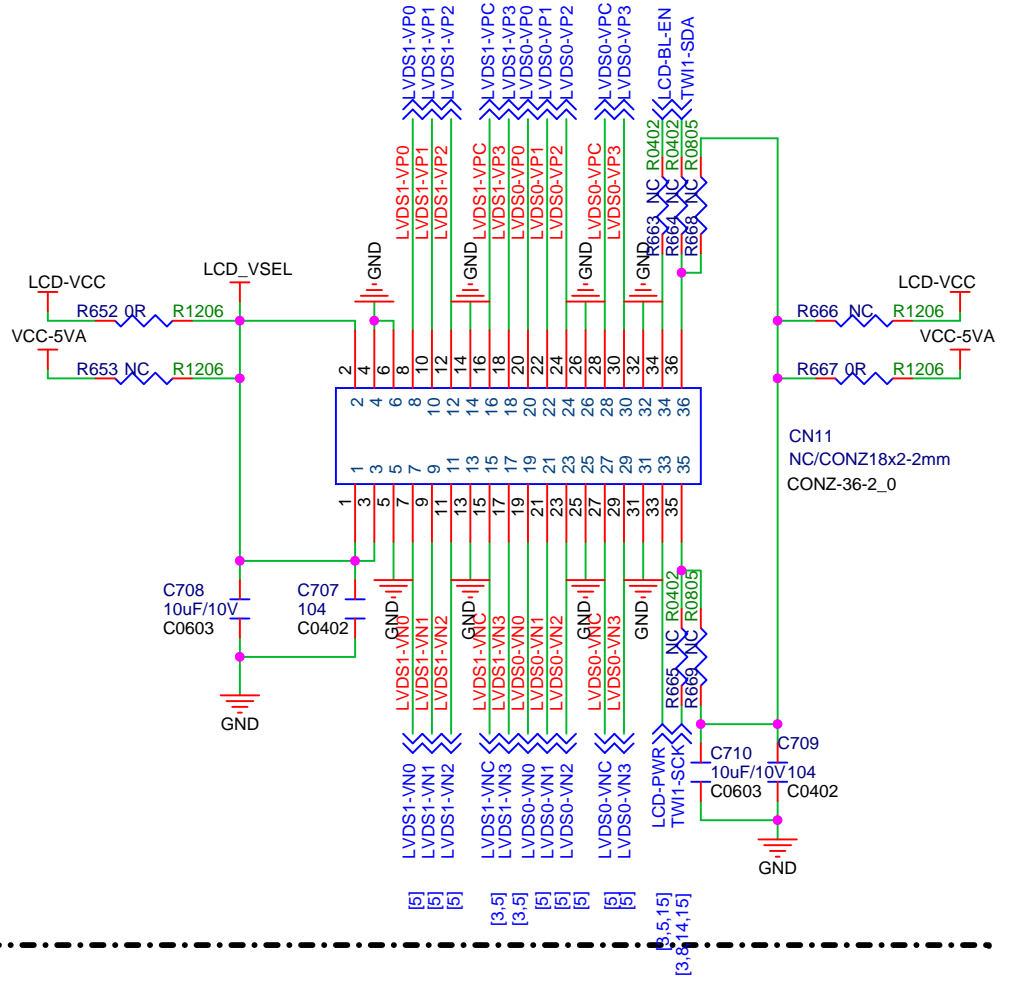

MIPI/DVP Camera

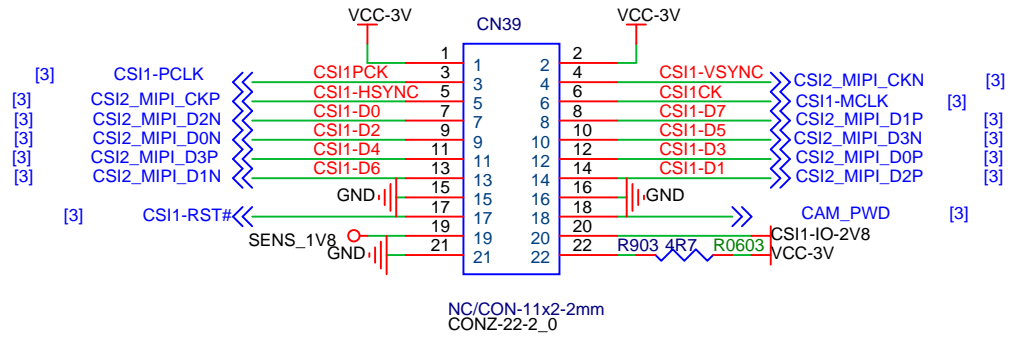



方糖电子
CUBIETECH LIMITED

Cubietech Limited
www.cubietech.com

| | | |
|----------------|-------------------------------|----------------|
| Title | | |
| Cubie AIO-S500 | | |
| Size | Document Number | Rev |
| A4 | LCD Con For LeHua | V10 |
| Date: | Wednesday, September 06, 2017 | Sheet 15 of 15 |