

JMS562

SuperSpeed USB and eSATA Gen3 to Dual SATA Gen3 Ports Bridge

Preliminary Datasheet

Revision 1.0.1

Revision History

Version	Date yyyy/mm/dd	Revision Description
1.0.1	2014/04/21	<ol style="list-style-type: none">1. Correct 1.1.1 typo2. Add 1.3.3 description3. Correct "XIN" description4. Correct "XOUT" description5. Correct "VREG-IN" description6. Correct "FB" description7. Correct Reset Timing
1.0.0	2013/10/31	Release revision 1.0.0

© Copyright JMicon Technology 2014.

All Rights Reserved.

Printed in Taiwan 2014

JMicron and the JMicon Logo are trademarks of JMicon Technology Corporation in Taiwan and/or other countries. Other company, product and service names may be trademarks or service marks of others.

All information contained in this document is subject to change without notice. The products described in this document are NOT intended for use implantation or other life supports application where malfunction may result in injury or death to persons. The information contained in this document does not affect or change JMicon's product specification or warranties. Nothing in this document shall operate as an express or implied license or environments, and is presented as an illustration. The results obtained in other operating environments may vary.

THE INFORMATION CONTAINED IN THIS DOCUMENT IS PROVIDED ON AN "AS IS" BASIS. In no event will JMicon be liable for damages arising directly or indirectly from any use of the information contained in this document.

JMicon Technology Corporation
1F, No.13, Innovation Road 1,
Hsinchu Science Park,
Hsinchu, Taiwan, R.O.C

For more information on JMicon products, please visit the JMicon website at <http://www.JMicon.com> or send email to sales@jmicron.com

Table of Contents

1. Overviews	5
1.1 FUNCTION OVERVIEW	5
1.1.1 FEATURES	5
1.1.2 BLOCK DIAGRAM	6
1.2 SUPPORT DEVICES.....	7
1.3 APPLICATION EXAMPLES.....	7
1.3.1 USB 2.0, USB 3.0 and eSATA to 2 SATA Gen3 HDDs	7
1.3.2 USB 2.0 and USB 3.0 to three SATA Gen3 HDDs.....	7
1.3.3 USB 2.0, USB 3.0 and 2 eSATA to SATA Gen3 HDD	8
2. Package Pin-Out	9
2.1 PIN TYPE DEFINITION	10
2.2 PIN DESCRIPTION	10
3. External SPI Flash.....	15
4. Clock & Reset.....	16
4.1 Crystal input.....	16
4.2 Reset input	16
5. Electrical Characteristics	17
5.1 Absolute Maximum Rating.....	17
5.2 Recommended Power Supply Operation Conditions.....	17
5.3 Recommended External Clock Source Conditions	17
5.4 Power Supply DC Characteristics.....	18
5.4.1 USB2.0 to SATAx2 mode	18
5.4.2 USB3.0 to SATAx2 mode	19
5.5 I/O DC Characteristics	19
5.6 Power-On Sequence	20
6. Internal Switch Regulator	22
7. Performance Benchmark.....	23
8. Package Dimension	24

1. Overviews

1.1 FUNCTION OVERVIEW

1.1.1 FEATURES

- Complies with Serial ATA International Organization: Serial ATA Revision 3.1
- Complies with Universal Serial Bus 3.0 Specification Revision 1.0
- Complies with USB Mass Storage Class Bulk-Only Transport (BOT) Rev. 1.0 Specification
- Complies with USB Attached SCSI Protocol (UASP) Rev. 1.0 Specification
- Supports USB Super-Speed/High-Speed/Full-Speed Operation
- Supports USB 2.0/USB 3.0 power saving mode
- Supports multi LUNs for USB 2.0/USB 3.0
- Supports port multiplier for eSATA
- Supports hardware RAID0 (striping) and RAID1 (mirror) over USB 2.0/USB 3.0/eSATA
- Flexible GPIOs for customized functions
- Provides a hardware control PWM
- Provides software utilities for downloading the upgraded firmware code under USB2.0/USB3.0/eSATA
- Design for Windows XP, Windows 7, Windows 8, MAC 10.3 or later versions
- 30MHz external crystal
- An embedded 3.3V to 1.2V voltage regulator
- An embedded 5.0V to 3.3V voltage regulator
- QFN 76 package

1.1.2 BLOCK DIAGRAM

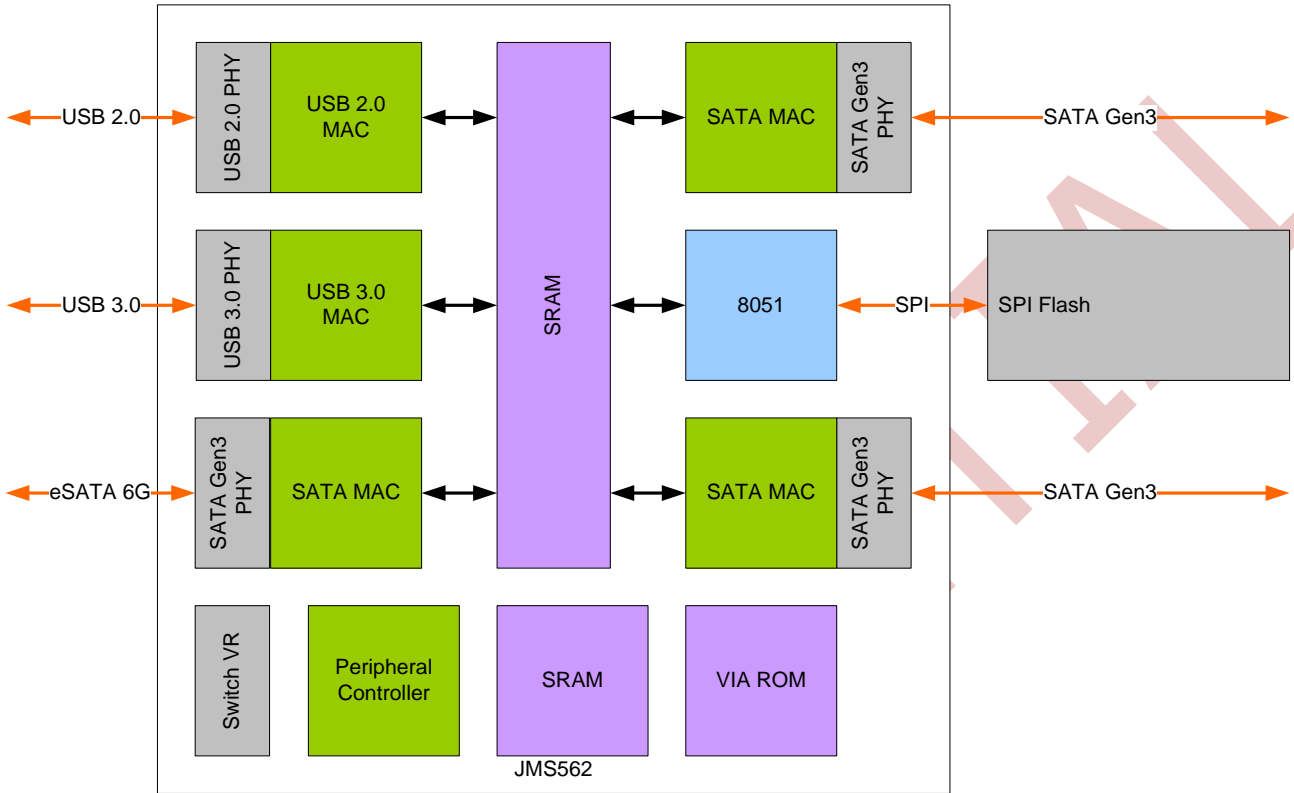

1.2 SUPPORT DEVICES

- Hard disk drives

1.3 APPLICATION EXAMPLES

1.3.1 USB 2.0, USB 3.0 and eSATA to 2 SATA Gen3 HDDs

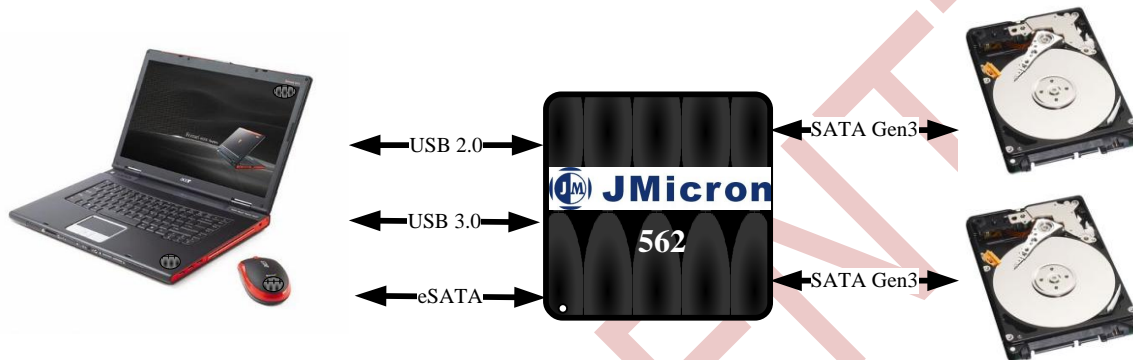

1.3.2 USB 2.0 and USB 3.0 to three SATA Gen3 HDDs

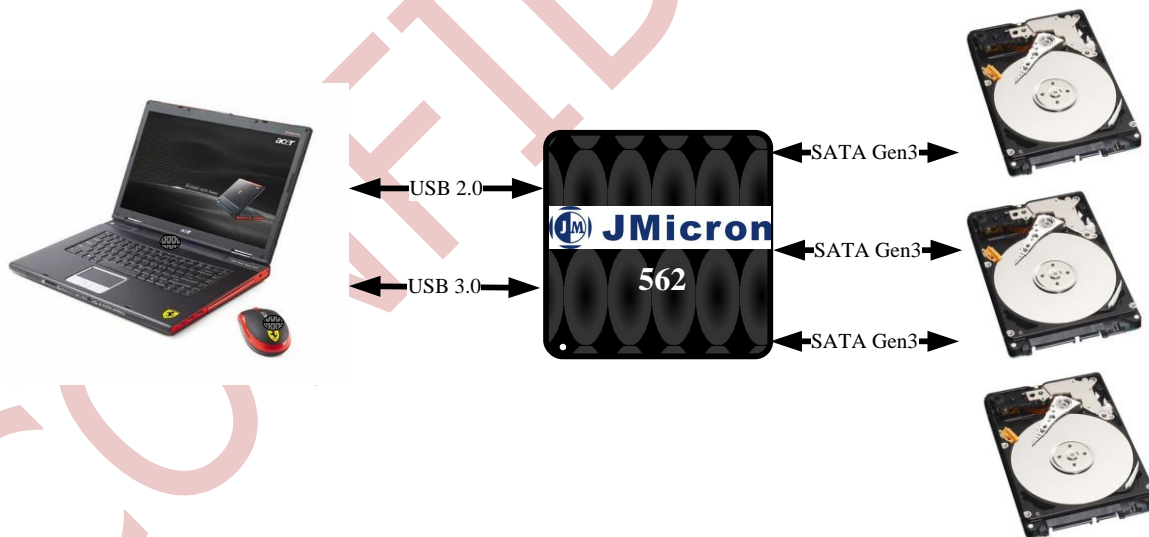

1.3.3 USB 2.0, USB 3.0 and 2 eSATA to SATA Gen3 HDD

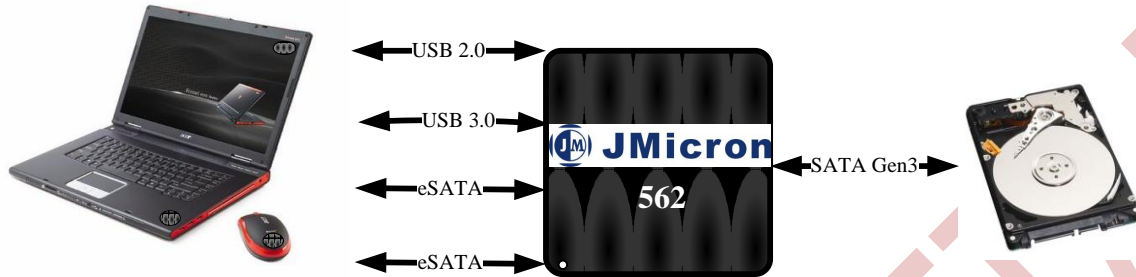

CONFIDENTIAL

2. Package Pin-Out

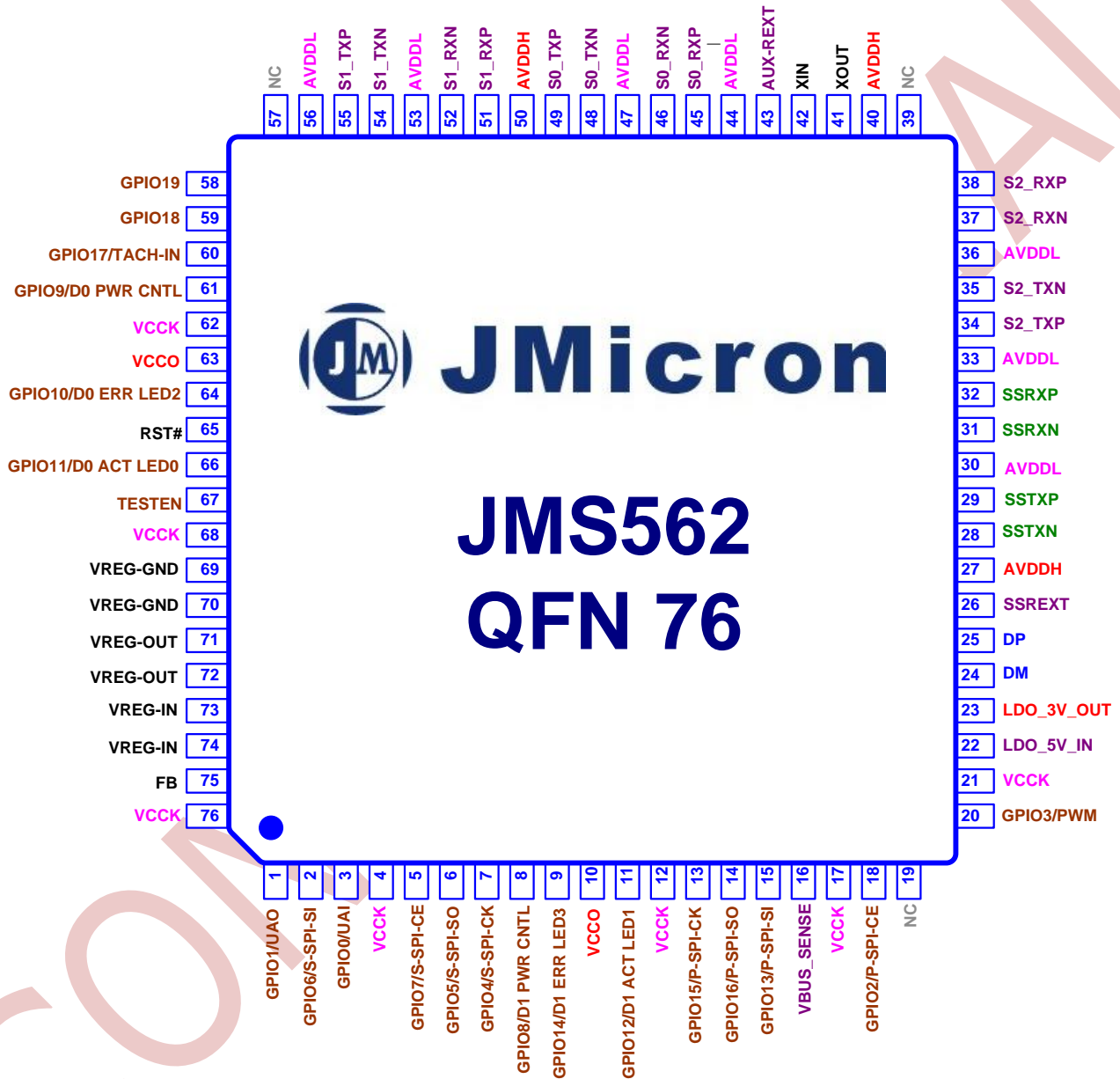

2.1 PIN TYPE DEFINITION

Pin Type	Definition
A	Analog
D	Digital
I	Input
O	Output
IO	Bi-directional
S	Internal Schmitt Trigger Circuit is used
L	Internal weak pull-low (Max. 164K Ω , Typical 96 K Ω , Min. 61K Ω)
H	Internal weak pull-high (Max. 141K Ω , Typical 93 K Ω , Min. 66K Ω)

2.2 PIN DESCRIPTION

Signal Name	QFN 76	Type	Description
Serial ATA interface			
S0_RXP	45	AI	SATA Port RX+ Signal. A 10nF capacitor should be connected between this pin and SATA connector.
S0_RXN	46	AI	SATA Port RX- Signal. A 10nF capacitor should be connected between this pin and SATA connector.
S0_TXP	49	AO	SATA Port TX+ Signal. A 10nF capacitor should be connected between this pin and SATA connector.
S0_TXN	48	AO	SATA Port TX- Signal. A 10nF capacitor should be connected between this pin and SATA connector.
S1_RXP	51	AI	SATA Port RX+ Signal. A 10nF capacitor should be connected between this pin and SATA connector.
S1_RXN	52	AI	SATA Port RX- Signal. A 10nF capacitor should be connected between this pin and SATA connector.
S1_TXP	55	AO	SATA Port TX+ Signal. A 10nF capacitor should be connected between this pin and SATA connector.
S1_TXN	54	AO	SATA Port TX- Signal. A 10nF capacitor should be connected between this pin and SATA connector.
S2_RXP	38	AI	SATA Port RX+ Signal. A 10nF capacitor should be connected between this pin and SATA connector.

Signal Name	QFN 76	Type	Description
S2_RXN	37	AI	SATA Port RX- Signal. A 10nF capacitor should be connected between this pin and SATA connector.
S2_TXP	34	AO	SATA Port TX+ Signal. A 10nF capacitor should be connected between this pin and SATA connector.
S2_TXN	35	AO	SATA Port TX- Signal. A 10nF capacitor should be connected between this pin and SATA connector.
REXT	43	AI	External Reference Resistance. A 12K Ω \pm 1% external resistor should be connected to this pin.
USB 3.0 interface			
SSRXP	32	AI	Super Speed RX+ Signal.
SSRXN	31	AI	Super Speed RX- Signal.
SSTXP	29	AO	Super Speed TX+ Signal. A 100nF capacitor should be connected between this pin and USB connector.
SSTXN	28	AO	Super Speed TX- Signal. A 100nF capacitor should be connected between this pin and USB connector.
SSREXT	26	AI	External Reference Resistance. A 12K Ω \pm 1% external resistor should be connected to this pin.
USB 2.0 interface			
DM	24	AIO	USB 2.0 Bus D- Signal.
DP	25	AIO	USB 2.0 Bus D+ Signal.
LDO_5V_IN	22	AI	5V to 3.3V LDO Power Input. This pin should be connected to the 5V input or USB connector 5V.
LDO_3V_OUT	23	AO	Capacitance for internal LDO of USB 2.0. A capacitance to ground is recommended on this pin. The value should be 1 μ F. The output voltage range is 3.3V \pm 10%.
VBUS_SENSE	16	AI	USB 2.0/USB 3.0 Cable Power Input This pin should be connected to USB connector 5V.
Crystal Interface			
XIN	42	AI	Crystal Input/Oscillator Input. It is connected to a 30MHz crystal or crystal oscillator. The variation range should be \pm 30ppm. And the input voltage should range in 3.3V \pm 5%.

Signal Name	QFN 76	Type	Description
XOUT	41	AO	Crystal Output. It is connected to a crystal. While crystal oscillator is applied, this pin should be reserved as No Connection (NC). The output variation range is around $\pm 30\text{ppm}$ (input dependent). And the output voltage range is $3.3\text{V}\pm 5\%$ (input dependent).
Switching Regulator			
VREG-GND	69,70	AI	Switching Regulator Ground.
VREG-OUT	71,72	AO	Switch Output Pin. An external inductor should be connected to this pin.
VREG-IN	73,74	AI	Switching Regulator 3.3V Power Supply.
FB	75	AI	Feedback pin which is connected to 1.2V core voltage.
Control and GPIOs			
RST#	65	DIS	System Global Reset Input. Active-low to reset the entire chip. An external RC should be connected to this pin. Please refer to the following section for detailed description.
TESTEN	67	DIS	MP Test Mode Enable. This pin is reserved for IC mass production testing. Please set this pin to low under normal operation.
GPIO[0]	3	DIOH	8051 UART Input / GPIO [0]. This pin only preserves for UART function.
GPIO[1]	1	DIOH	8051 UART Output / GPIO [1]. This pin can be programmed by customized firmware and also be programmed to the UART interface by customized firmware.
GPIO[2]	18	DIOH	Primary Serial Flash (CE) / GPIO [2] This pin only preserves for SPI chip enable.
GPIO[3]	20	DIOH	GPIO [3]. This pin only preserves for FAN function.
GPIO[4]	7	DIOH	Secondary Serial Flash (SCK) / GPIO [4] This pin can be programmed as special function or normal GPIO function.
GPIO[5]	6	DIOH	Secondary Serial Flash (SO) / GPIO [5] This pin can be programmed as special function or normal GPIO function.
GPIO[6]	2	DIOH	Secondary Serial Flash (SI) / GPIO [6] This pin only preserves for UART function.
GPIO[7]	5	DIOH	Secondary Serial Flash (CE) / GPIO [7] This pin can be programmed as special function or normal GPIO function.

Signal Name	QFN 76	Type	Description
GPIO[8]	8	DIOH	GPIO [8]. This pin only preserves for enable hard drive power.
GPIO[9]	61	DIOH	GPIO [9]. This pin only preserves for enable hard drive power.
GPIO[10]	64	DIOH	GPIO [10]. This pin can be programmed by customized firmware.
GPIO[11]	66	DIOH	GPIO [11]. This pin can be programmed by customized firmware.
GPIO[12]	11	DIOH	GPIO [12]. This pin can be programmed by customized firmware.
GPIO[13]	15	DIOH	Primary Serial Flash (SI) / GPIO [13] This pin can be programmed as special function or normal GPIO function.
GPIO[14]	9	DIOH	GPIO [14]. This pin can be programmed by customized firmware.
GPIO[15]	13	DIOH	Primary Serial Flash (SCK) / GPIO [15] This pin can be programmed as special function or normal GPIO function.
GPIO[16]	14	DIOH	Primary Serial Flash (SO) / GPIO [16] This pin can be programmed as special function or normal GPIO function.
GPIO[17]	60	DIOH	GPIO [17]. This pin only preserves for FAN function.
GPIO[18]	59	DIOH	GPIO [18]. This pin can be programmed by customized firmware.
GPIO[19]	58	DIOH	GPIO [19]. This pin can be programmed by customized firmware.
Power and Ground			
VCCO	10,63	P	Digital I/O Power Supply.
VCCK	4,12, 17 21, 62, 68 76	P	Digital Core Power Supply.
AVDDH	27,40, 50	P	Analog I/O Power Supply.
AVDDL	30, 33, 36 44, 47, 53 56	P	Analog Core Power Supply.

Signal Name	QFN 76	Type	Description
Other			
NC	19,39, 57	--	Not Connected or Connected to Ground.

LED Indicator

If user has an application for LED function, please contact JMicon's AE before PCB layout.

GPIO initial value

All GPIOs set as input mode with pull-high resistor while in reset.

CONFIDENTIAL

3. External SPI Flash

Vendor Name	Model Name	Comment
MXIC	25L400 1E	
MXIC	25L4005 AMC	
MXIC	25L1605 DM2I	
MXIC	25L8005 MC	
MXIC	25L4006E	
MXIC	25L8006E	
MXIC	25L8035E	
AMIC	A25L040M-F	
AMIC	A25L016M-F	
AMIC	A25L032M-F	
Winbond	W25X40BLSNIG	
Winbond	25X40CLNIG	
Winbond	25Q80BLNIG	
Winbond	25X40CLVIG	
Giga Device	25Q40T	
vpowerwins	FM25F04	
ESMT	F25L04PAG1SM	

4. Clock & Reset

4.1 Crystal input

Single crystal input at 30MHz is needed.

4.2 Reset input

The reset input pin is the Schmitt trigger input pin. All functions will be initialized by reset except the Analog Power-On Reset Circuit depending on the Power on-off.

CONFIDENTIAL

5. Electrical Characteristics

5.1 Absolute Maximum Rating

Parameter	Symbol	Condition	Min	Max	Unit
Digital I/O power supply	VCCO _(ABS)		-0.3	3.47	V
Digital core power supply	VCKK _(ABS)		-0.3	1.26	V
Analog I/O power supply	AVDDH _(ABS)		-0.3	3.47	V
Analog core power supply	AVDDL _(ABS)		-0.3	1.26	V
USB VBUS power supply	VBUS		-0.3	5.5	V
Digital I/O input voltage	V _{I(D)}		-0.3	3.47	V
Storage Temperature	T _{STORAGE}		-40	150	°C

5.2 Recommended Power Supply Operation Conditions

Parameter	Symbol	Condition	Min	Typical	Max	Unit
Digital I/O power supply	VCCO		3.13	3.3	3.47	V
Digital core power supply	VCKK		1.14	1.2	1.26	V
Analog I/O power supply	AVDDH		3.13	3.3	3.47	V
Analog core power supply	AVDDL		1.14	1.2	1.26	V
Digital I/O input voltage	V _{I(D)}		0	3.3	3.47	V
Ambient operation temperature	T _A		0		70	°C
Junction Temperature	T _J		-40		125	°C

5.3 Recommended External Clock Source Conditions

Parameter	Symbol	Condition	Min	Typical	Max	Unit
External reference clock				30		MHz
Clock Duty Cycle			45	50	55	%

5.4 Power Supply DC Characteristics

The maximum and minimum values are measured at the max and min power supply levels respectively.

5.4.1 USB2.0 to SATAx2 mode

@S0 state

Parameter	Symbol	Condition	Min	Typical	Max	Unit
3.3V power supply	VCCO and ACDDH	Operate @3.3V	40.6	47.9	55.1	mA
1.2V power supply	VCCK and AVDDL	Operate @1.2V	315.5	319.6	323.1	mA

@S4 state

Parameter	Symbol	Condition	Min	Typical	Max	Unit
3.3V power supply	VCCO and ACDDH	Operate @3.3V	18.5	18.6	18.6	mA
1.2V power supply	VCCK and AVDDL	Operate @1.2V	207.8	209.1	210.0	mA

5.4.2 USB3.0 to SATAx2 mode

@U0 state

Parameter	Symbol	Condition	Min	Typical	Max	Unit
3.3V power supply	VCCO and ACDDH	Operate @3.3V	44.9	53.1	60.3	mA
1.2V power supply	VCCK and AVDDL	Operate @1.2V	437.8	439.3	441.4	mA

@U3 state (suspend @S4)

Parameter	Symbol	Condition	Min	Typical	Max	Unit
3.3V power supply	VCCO and ACDDH	Operate @3.3V	28.4	28.4	28.4	mA
1.2V power supply	VCCK and AVDDL	Operate @1.2V	324.4	325	325.6	mA

5.5 I/O DC Characteristics

Parameter	Symbol	Condition	Min	Typical	Max	Unit
Input low voltage	V_{IL}				0.7	V
Input high voltage	V_{IH}		1.5			V
Output low voltage	V_{OL}				0.3	V
Output high voltage	V_{OH}		1.9			V

5.6 Power-On Sequence

The Power-On sequence rules are defined in this section. Designers should follow all the rules for external power designs. Detailed explanations are listed as below.

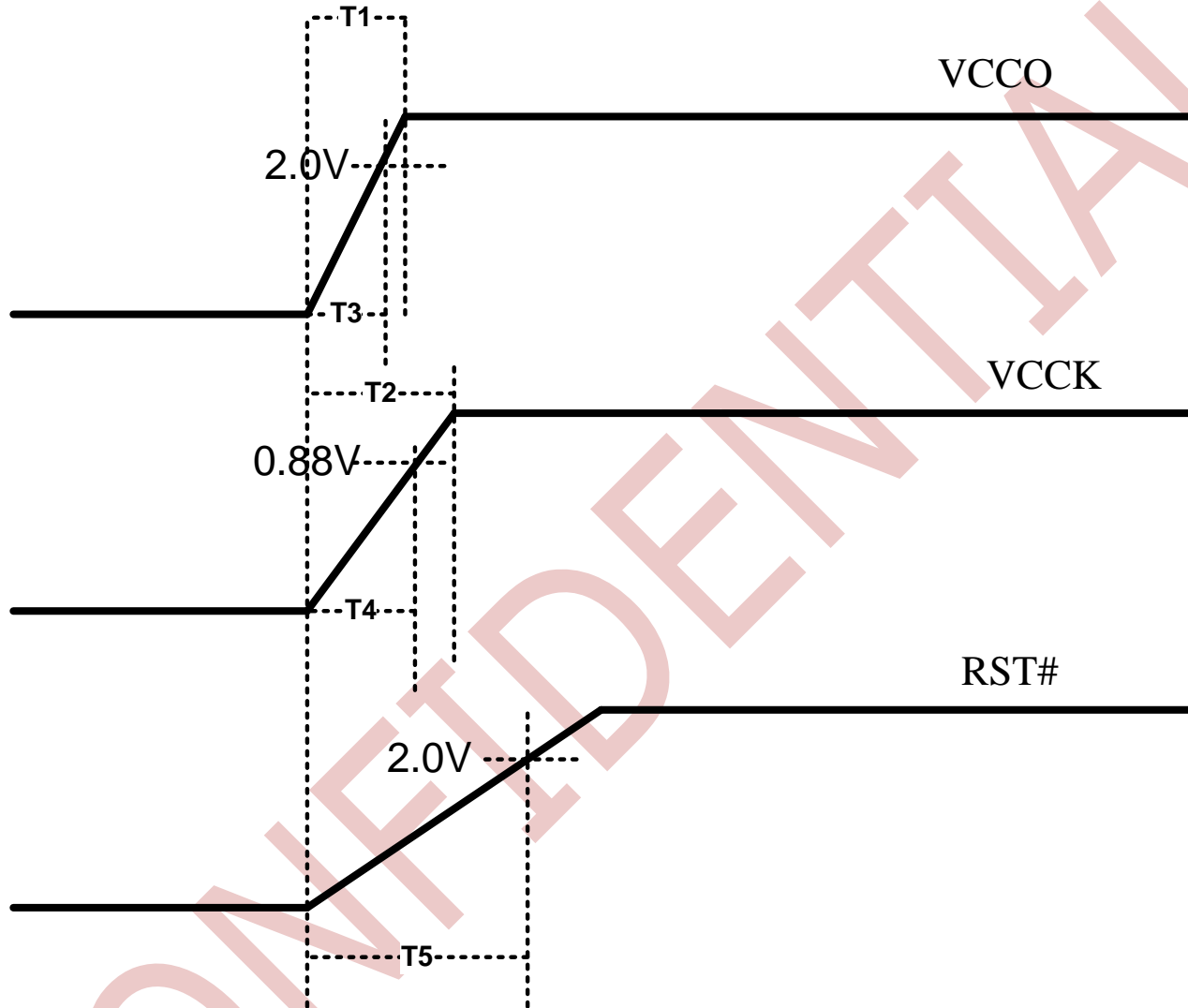

T1: Rise time for 3.3V power rail from 0.0V to 3.3V

T2: Rise time for 1.2V power rail from 0.0V to 1.2V

T3: Rise time for 3.3V power rail from 0.0V to 2.0V

T4: Rise time for 1.2V power rail from 0.0V to 0.88V

T5: Rise time for RST# signal from 0.0V to 2.0V

The recommended power sequence and timing requirements are listed as below.

Time	Minimum	Maximum
T1	0.0 ms	10 ms
T2	0.0 ms	10. ms
T3	0.0 ms	8 ms
T4	0.0 ms	8 ms
T5	100 ms	500 ms

The RESET timing constrain is based on the external RC reset circuits. In order to control the charge and discharge time for RC circuits, minimum and maximum requirements are listed. If designers apply timing control chip to control the reset signal, the only requirement will be minimum value. In other words, the maximum value can be skipped without problems.

6. Internal Switch Regulator

Input Voltage Range: 2.375V ~ 5.500V

Output Voltage Range: 1.0V ~ 1.4 (programmable)

Output Voltage Accuracy : $I_{LOAD}= 650mA$, $V_{OUT}\pm 10\%$

Max. Output Current : 650mA

Over-Current Protection (OCP): Yes (1,500mA)

Output Capacitor: 20uF

Output Inductor: 3.3uH

Start-up Time : < 1.5 ms

Thermal Shutdown: No

Faster Shutdown: No

CONFIDENTIAL

7. Performance Benchmark

USB3.0 UAS Performance 400 MB/s

USB2.0 UAS Performance 42 MB/s

CONFIDENTIAL

8. Package Dimension

- QFN 76 9x9 mm²

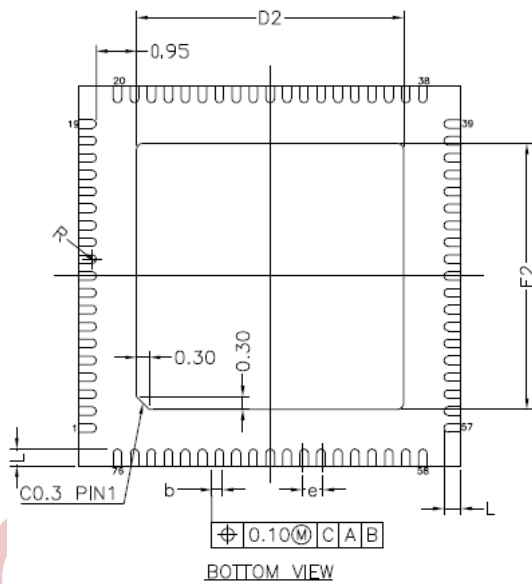
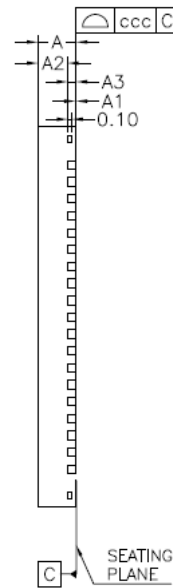
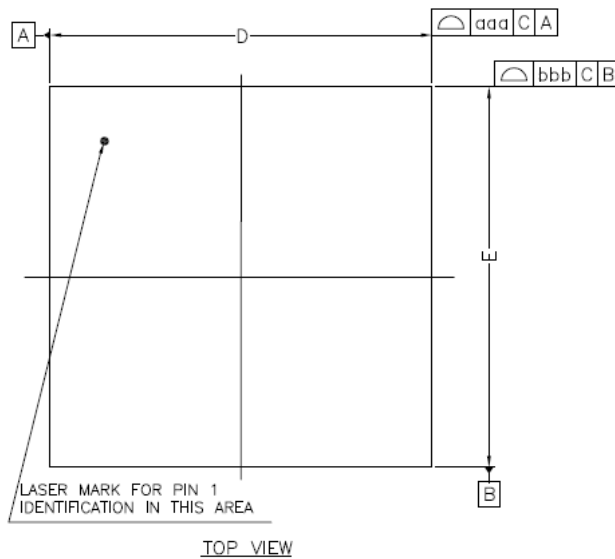

* CONTROLLING DIMENSION : MM

SYMBOL	MILLIMETER			INCH		
	MIN.	NOM.	MAX.	MIN.	NOM.	MAX.
A	0.80	0.85	0.90	0.031	0.033	0.035
A1	0.00	0.035	0.05	0.00	0.001	0.002
A2	---	0.65	0.70	---	0.026	0.028
A3	0.203 REF.			0.008 REF.		
b	0.15	0.20	0.25	0.006	0.010	0.010
D	9.00 bsc			0.354 bsc		
D2	6.20	6.30	6.40	0.244	0.248	0.252
E	9.00 bsc			0.354 bsc		
E2	6.20	6.30	6.40	0.244	0.248	0.252
L	0.35	0.40	0.45	0.014	0.016	0.018
e	0.40 bsc			0.016 bsc		
R	0.08	---	---	0.003	---	---
TOLERANCES OF FORM AND POSITION						
aaa	0.10		0.004			
bbb	0.10		0.004			
ccc	0.05		0.002			